

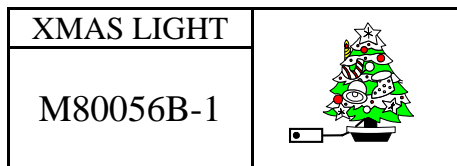

8 FUNCTIONS
XMAS LIGHT CONTROL

8 段 功 能 单 键
圣 诞 灯 串 控 制 IC



FEATURES 功能叙述

- 1 key operation.
- Operation mode: 8 modes.
- Direct drive SCR.

MODE	FUNCTIONS	功能
1	COMBINATION	第二段到第七段
2	IN WAVES	2种 波浪前进后退
3	SEQUENTIAL	4种 跑马
4	SLO-GOL	3种 单灯渐明渐暗
5	CHASING / FLASH	跑马前进后退, 星星闪烁
6	SLOW FADE	3种 四灯同时渐明渐暗
7	TWINKLE / FLASH	星星闪烁, 跑马
8	STEADY ON	灯串固定不闪

APPLICATION 产品应用

- Xmas light controller, any AC control toy.

ELECTRICAL CHARACTERISTICS 电气规格

(@V_{DD}=4V unless otherwise specified)

Characteristics	Sym.	Min.	Typ.	Max.	Unit	REMARKS
工作电压 Operating Voltage	V _{DD}	3	4	5	V	
工作电流 Operating Current	I _{OP}	—	—	2	mA	No load
静态电流 Quiescent Current	I _{SB}	—	—	—	μ A	
推动电流 BZ Driving Current	I _{OH}	—	0.2	—	mA	@V _{DS} =1V
振荡频率 Oscillator Frequency	F _{OSC}	—	125	—	KHz	± 30% TOL.
工作温度 Operating Temperature	Temp.	0	25	60	°C	

APPLICATION DIAGRAM 参考电路图

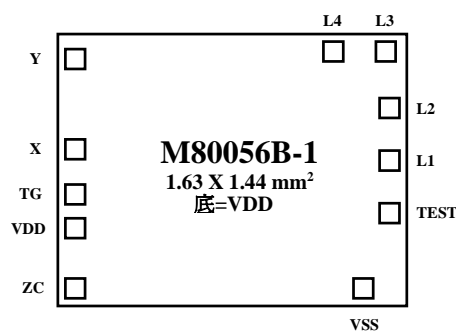
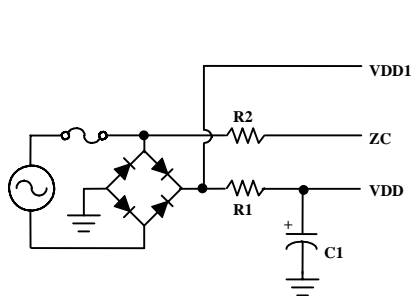

	AC110V 60Hz	AC220V 50Hz	AC24V 50Hz
R1	82K Ω	180K Ω	20K Ω
R2	1M	1M	1M
C1	47 μ /16V	47 μ /16V	47 μ /16V
Rosc	200K Ω	220K Ω	240K Ω

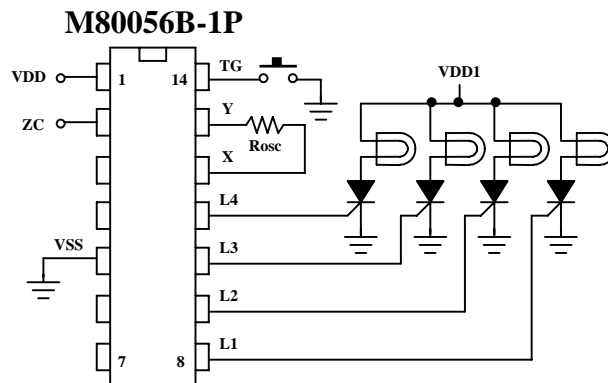

* All specs and applications shown above subject to change without prior notice.

(以上电路及规格仅供参考,本公司得径行修正)



8 FUNCTIONS
XMAS LIGHT CONTROL

8 段功能单键
圣诞灯串控制 IC

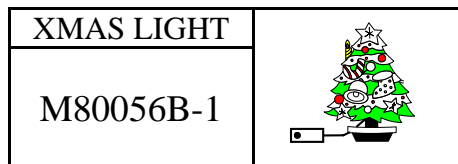

PAD ASSIGNMENT & POSITION

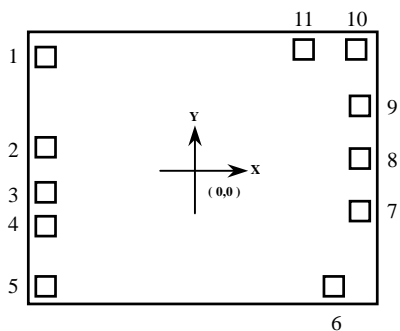

UNIT : um

No.	NAME	X	Y
1	OSC2	-654	463
2	OSC1	-654	79
3	TG	-654	-107
4	VDD	-654	-261
5	ZC	-654	-510
6	VSS	543	-507
7	TEST	656	-187
8	L1	651	37
9	L2	642	259
10	L3	625	504
11	L4	405	504

* CHIP SIZE ~ 1.63 x 1.44 mm²

* IC substrate should be connected to VDD in PCB (PCB 上 IC 必须接 VDD)