

REMOTE FAN CONTROL

遥控风扇控制 IC

FEATURES 功能叙述

- 定时 TM TIMER : 0.5/1/2/4 HR.
- 速度 SP SPEED : S, M, L.
- 风类 MD MODE : NORMAL, RHYTHM, SLEEPING.
- 摆动 HD SWING : SO1, SO2.
- 电源 OFF : ON/OFF CONTROL.
- XTAL : 455 KHz.

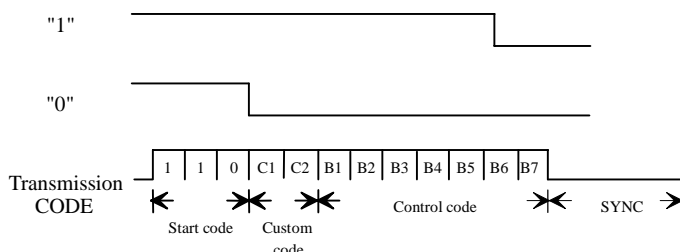

APPLICATION 产品应用

- Fan control, Light control etc..

ELECTRICAL CHARACTERISTICS 电气规格

( @V<sub>SS</sub>=-5V unless otherwise specified )

| Characteristics            | Sym.             | Min. | Typ. | Max. | Unit | REMARKS                 |
|----------------------------|------------------|------|------|------|------|-------------------------|
| 工作电压 Operating Voltage     | V <sub>SS</sub>  | -3   | -5   | -5.5 | V    |                         |
| 工作电流 Operating Current     | I <sub>OP</sub>  | —    | 0.1  | 0.5  | mA   | No load                 |
| 静态电流 Quiescent Current     | I <sub>SB</sub>  | —    | —    | —    | μA   |                         |
| 推动电流 Driving Current       | I <sub>OL</sub>  | —    | 10   | —    | mA   | @ V <sub>DS</sub> =1.2V |
| 振荡频率 Oscillator Frequency  | F <sub>OSC</sub> | —    | 455  | —    | KHz  | 32768 crystal or AC     |
| 工作温度 Operating Temperature | Temp.            | 0    | 25   | 60   | °C   |                         |

APPLICATION DIAGRAM 参考电路图

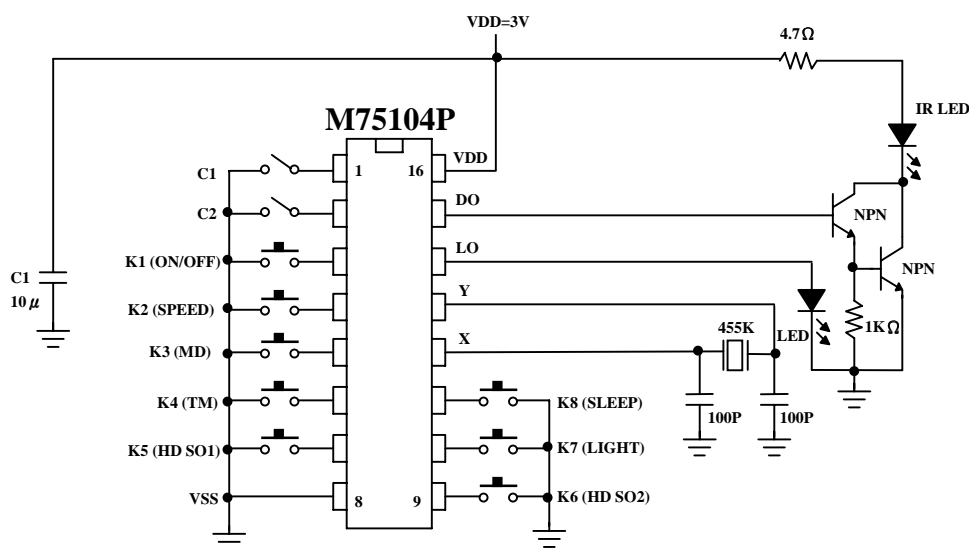

\* All specs and applications shown above subject to change without prior notice.  
( 以上电路及规格仅供参考,本公司得径行修正 )



FAN CONTROL

M75104/M78206

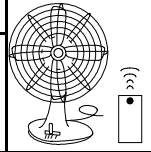

REMOTE FAN CONTROL

遙控風扇控制 IC

APPLICATION DIAGRAM 參考電路圖

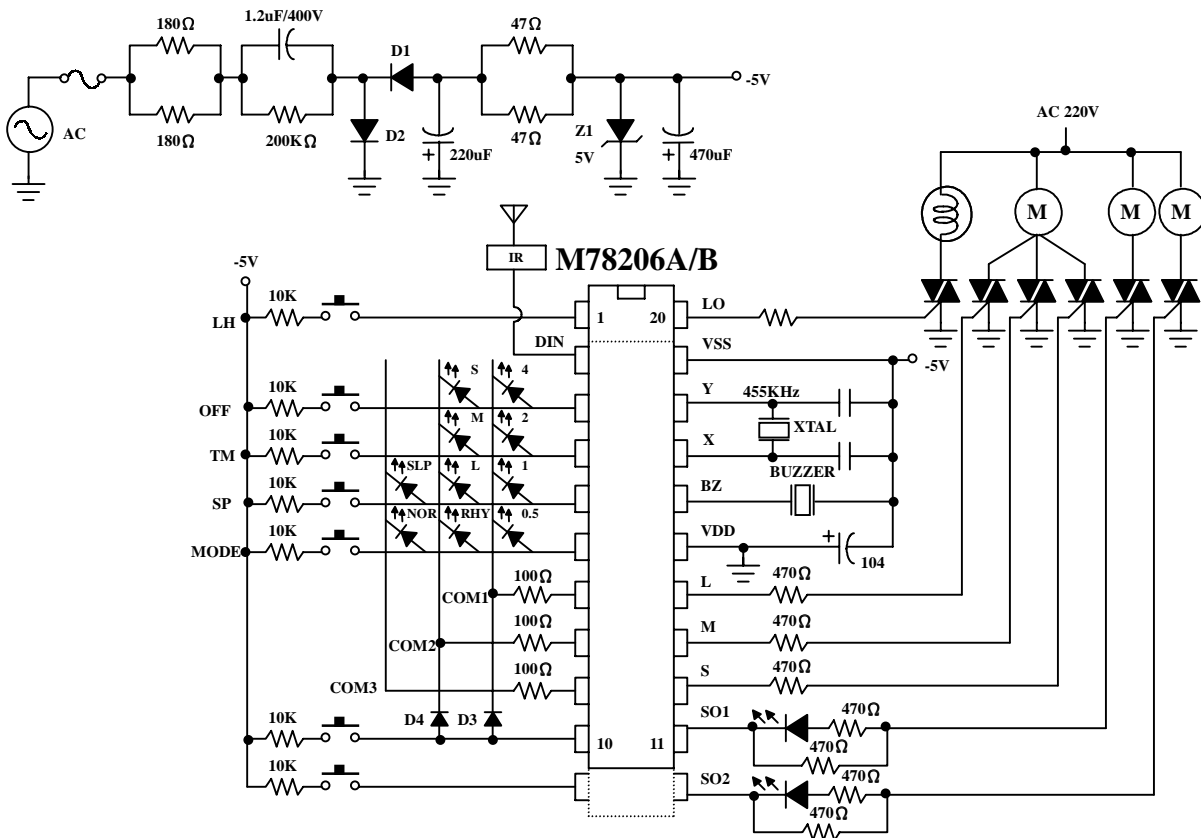

D3,D4 : Custom code  
"0" : Open  
"1" : Connect the diode

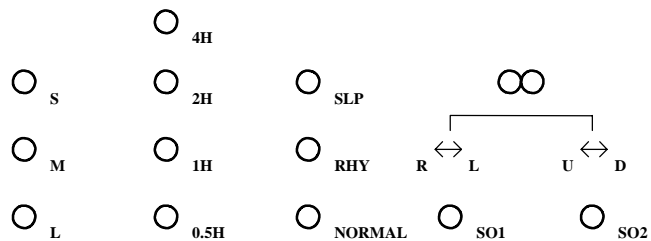

|                 |        |    |    |      |     |     |     |
|-----------------|--------|----|----|------|-----|-----|-----|
| ON/OFF Start-up | ON/OFF | SP | TM | MODE | SH1 | SH2 | LTI |
| SPD Start-up    | OFF    | SP | TM | MODE | SH1 | SH2 | LTI |

\* All specs and applications shown above subject to change without prior notice.

( 以上電路及規格僅供參考,本公司得徑行修正 )