



GENERAL DESCRIPTION 功能叙述

The M3DT/FT is a CMOS ASIC decoder. It will de-code the serial data from data input. The VT signal will go high and data will be copied to the output if address are checked the same. The address input are trinary i.e. LOW(0)、OPEN(X) and HIGH(1).

FEATURES 产品特长

- $3^{12} = 531,411$ codes, "0"、"X"、"1" Tri-states.
- 3 cycles checked each time
- S.O.Package: suffix-S.
- Address / Data types:
 - M3DT-L: Latch data outputs.
 - M3DT-M: Momentary data outputs.
 - M3FT: Full address type.

APPLICATIONS 产品应用

- Car/home alarm system, garage control etc..

BLOCK DIAGRAM 功能方块图

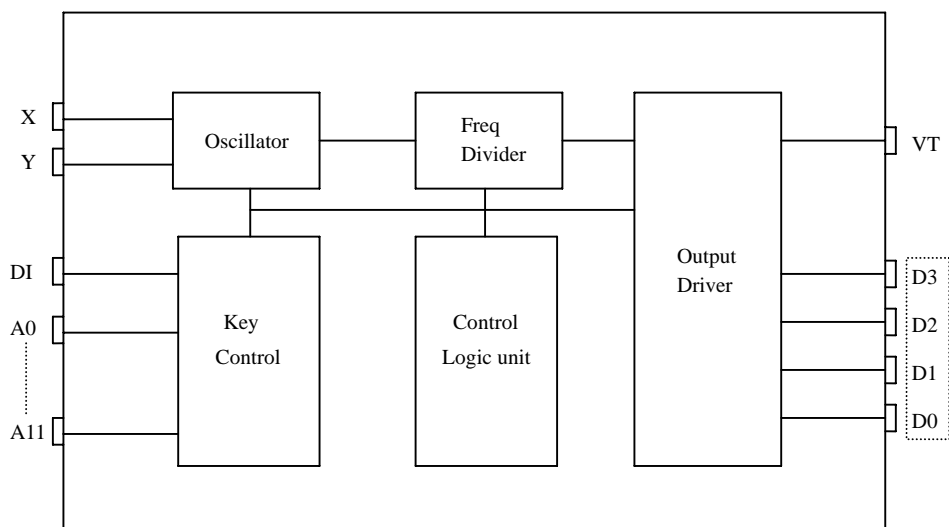

*All specs and applications shown above subject to change without prior notice.
(以上电路及规格仅供参考,本公司得径行修正)



3 STATES DECODER
3 态解碼 IC

EN/DECODER

M3DT/FT

ABSOLUTE MAXIMUM RATING

(TA=25°C)

Parameter	Rating	Unit
Supply Voltage	-0.3 to 5	V
Input Voltage	-0.2~V _{DD} +0.2	V
Operating Temperature	-20 to 70	°C
Storage Temperature	-50 to 125	°C

ELECTRICAL CHARACTERISTICS

Characteristics	Sym.	Min.	Typ.	Max.	Unit	Conditions
Operating Voltage	V _{DD}	—	3	5	V	
Operating Current	I _{OP}	—	0.3	1	mA	No load
Quiescent Current	I _{SB}	—	1	10	μ A	
Output Drive Current	I _O	—	2	—	mA	@V _{DS} =1.2V
Input Voltage	V _{IH}	V _{DD} -0.2	V _{DD}	V _{DD}	V	
	V _{IL}	V _{SS}	V _{SS}	V _{SS} +0.2		
Oscillator Frequency	Fosc	—	38	—	KHz	External ± 30%, R _{osc} =1.1M Ω

PIN DESCRIPTION

No.	M3DT	M3FT	Description
1~8	A0~A7	A0~A7	3 States address inputs
9	VSS	VSS	Negative power supply
10~13	D0~D3	A8~A11	Data outputs/Address inputs
14	DI	DI	Data input
15	X	X	Oscillator output
16	Y	Y	Oscillator input
17	VT	VT	Valid transmit
18	VDD	VDD	Positive power supply

M3DT/FT

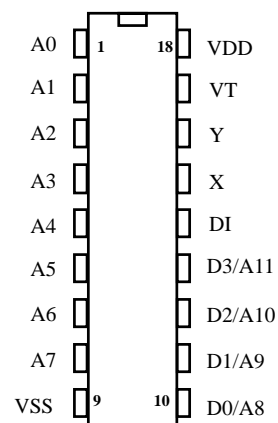



EN/DECODER
M3DT/FT

TIMING WAVEFORM

(1) Bit format

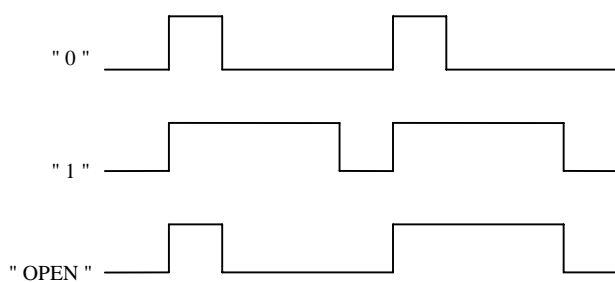

(2) TIMING DIAGRAM

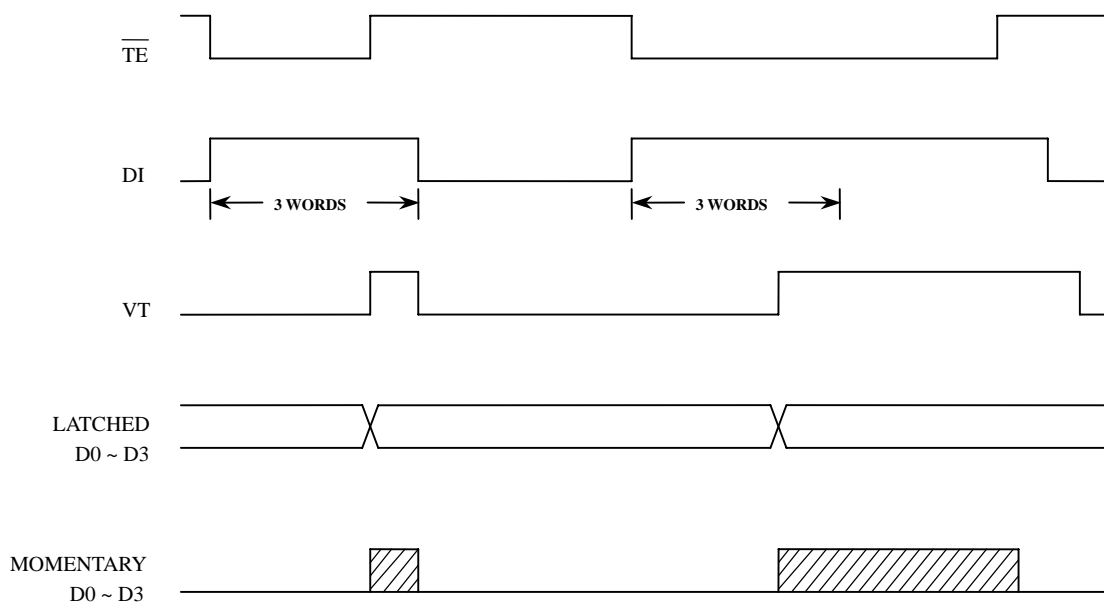



3 STATES DECODER

3 态 解 碼 IC

OPERATING FLOWCHART

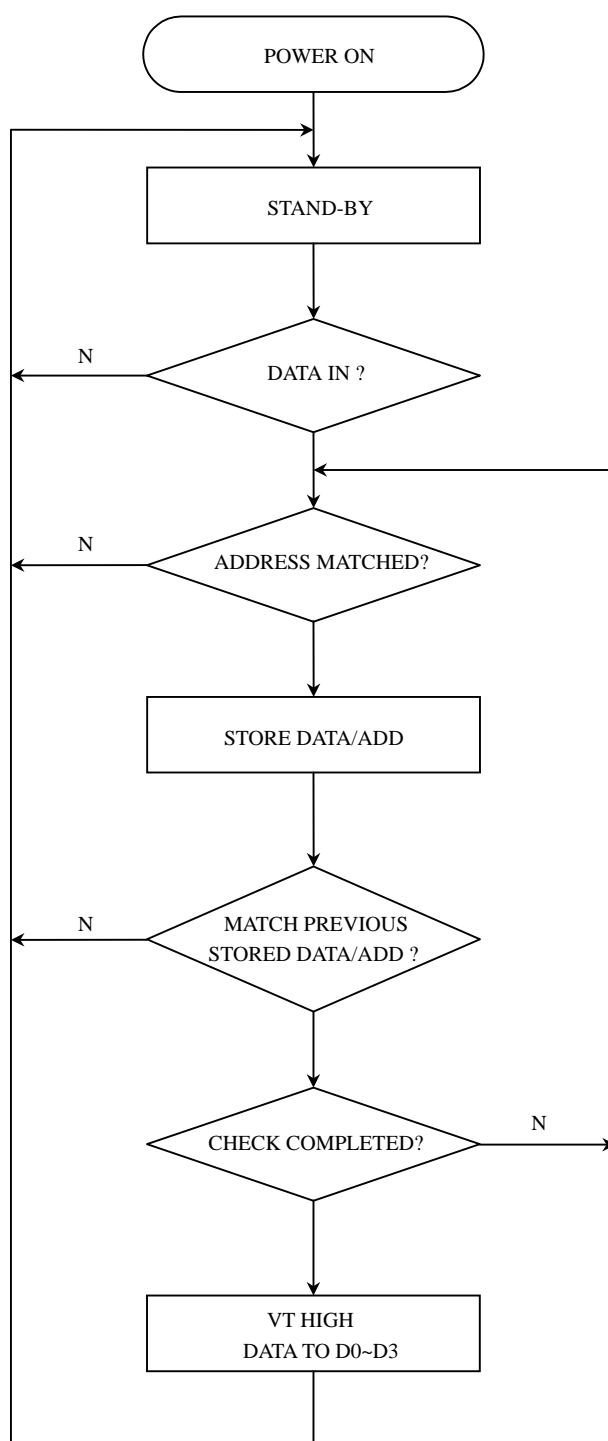



3 STATES DECODER
3 态解碼 IC

EN/DECODER

M3DT/FT

RECONNENDED OSCILLATOR PARAMETERS

Volt Rosc (KΩ)	M3DT/FT (KHz)			
	3V	4V	5V	6V
360K	51.9	65.9	66.8	67.2
320K	92	111	129	145
430K	39.6	55.9	57.2	57.5
1.1M	26	33	38	43
1.5M	25	27	30	33
2M	15	17	21	21

DATA OUTPUT

M3E, (D0~D3)	M3DT/FT (D0~D3)
0 (VSS)	0 (VSS)
X (OPEN)	1 (VDD)
1 (VDD)	1 (VDD)
POWER ON	0 (VSS)

M3DT/FT FREQ-VDD CURVE

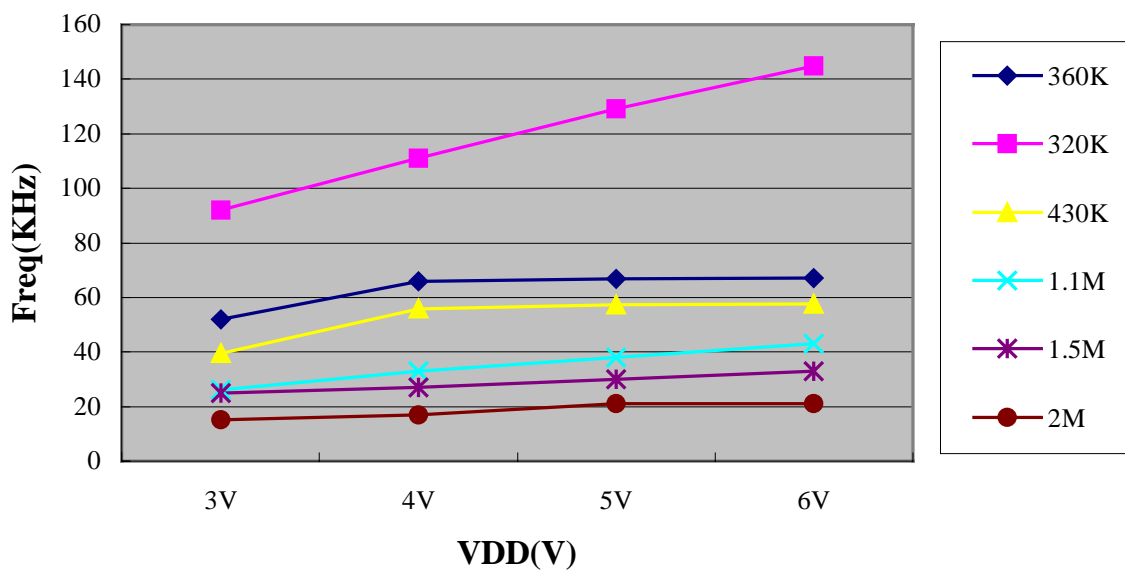



3 STATES DECODER
3 态解碼 IC

EN/DECODER

M3DT/FT

ADDRESS PIN INFORMATION

P/N	A0	A1	A2	A3	A4	A5	A6	A7	A8	A9	A10	A11
M3FT	A0	A1	A2	A3	A4	A5	A6	A7	A8	A9	A10	A11
M3DT-L1	A0	A1	A2	A3	A4	A5	A6	A7	A8	A9	A10	D0
M3DT-L2	A0	A1	A2	A3	A4	A5	A6	A7	A8	A9	D0	D1
M3DT-L3	A0	A1	A2	A3	A4	A5	A6	A7	A8	D0	D1	D2
M3DT-L4	A0	A1	A2	A3	A4	A5	A6	A7	D0	D1	D2	D3
M3DT-L5	A0	A1	A2	A3	A4	A5	A6	D0	D1	D2	D3	D5
M3DT-L6	A0	A1	A2	A3	A4	A5	D0	D1	D2	D3	D5	D6
M3DT-M1	A0	A1	A2	A3	A4	A5	A6	A7	A8	A9	A10	D0
M3DT-M2	A0	A1	A2	A3	A4	A5	A6	A7	A8	A9	D0	D1
M3DT-M3	A0	A1	A2	A3	A4	A5	A6	A7	A8	D0	D1	D2
M3DT-M4	A0	A1	A2	A3	A4	A5	A6	A7	D0	D1	D2	D3
M3DT-M5	A0	A1	A2	A3	A4	A5	A6	D0	D1	D2	D3	D5
M3DT-M6	A0	A1	A2	A3	A4	A5	D0	D1	D2	D3	D5	D6



3 STATES DECODER

3 态解碼 IC

APPLICATION DIAGRAM 参考电路图 (DIP, SOP)

(1) DATA TYPE

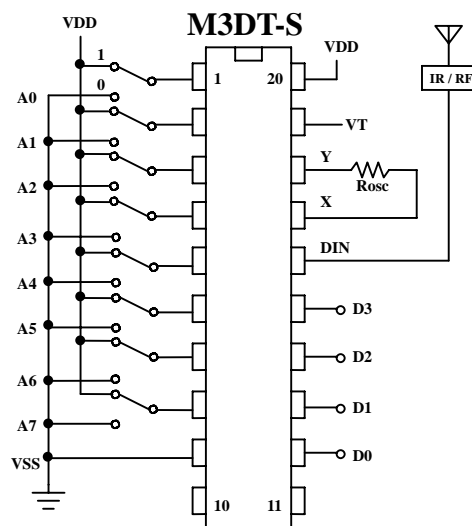
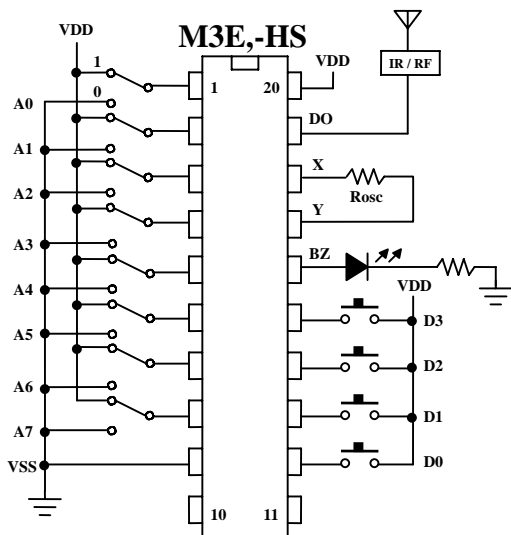
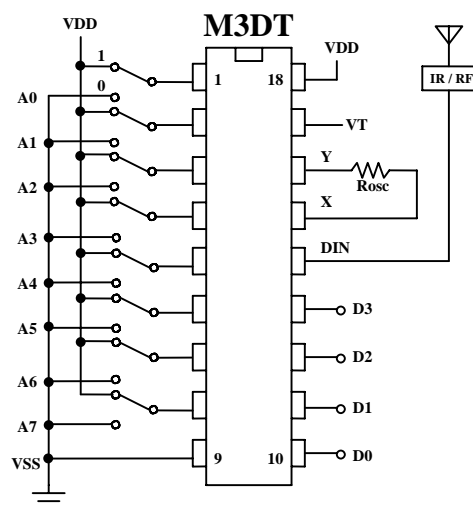
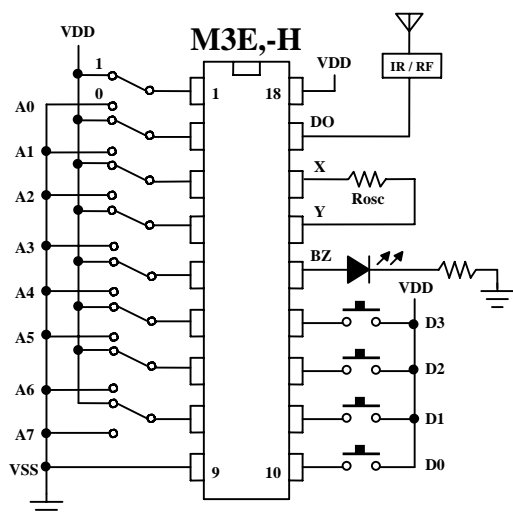



3 STATES DECODER

3 态解碼 IC

M3DT/FT

APPLICATION DIAGRAM 参考电路图 (DIP, SOP)

(2) FULL ADDRESS TYPE

