

MOBILE PHONE

大哥大專用 IC

FEATURES 功能敘述

- 8 different telephone sounds.
- Direct drive speaker or buzzer.
- Built-in oscillator.

SOUND	
K1	BEEP
K2	KEY TONE 1
K3	KEY TONE 2
K4	KEY TONE 3
K5	AUTO DIAL
K6	RING TONE
K7	BEEP 4 TIMES
K8	MELODY

APPLICATION 產品應用

- Alarm system, Toys, Key chain, Musical instrument, TV/Arcade game.

ELECTRICAL CHARACTERISTICS 電氣規格

( @V<sub>DD</sub>=3V unless otherwise specified )

Characteristics	Sym.	Min.	Typ.	Max.	Unit	REMARKS
工作電壓 Operating Voltage	V <sub>DD</sub>	—	3	3.5	V	
工作電流 Operating Current	I <sub>OP</sub>	—	0.1	0.5	mA	No load
靜態電流 Quiescent Current	I <sub>SB</sub>	—	1	5	μA	
推動電流 BZ Driving Current	I <sub>O</sub>	1	—	—	mA	@V <sub>DS</sub> =1V
推動電流 LO Driving Current	I <sub>OL</sub>	6	—	—	mA	@V <sub>DS</sub> =1.2V
振盪頻率 Oscillator Frequency	F <sub>OSC</sub>	—	85	—	KHz	±30% TOL.
工作溫度 Operating Temperature	Temp.	0	25	60	°C	

APPLICATION DIAGRAM 參考電路圖

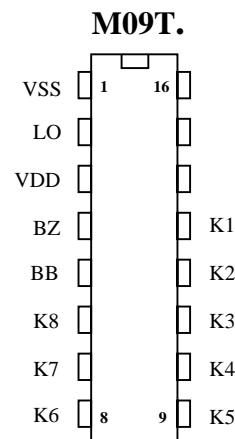
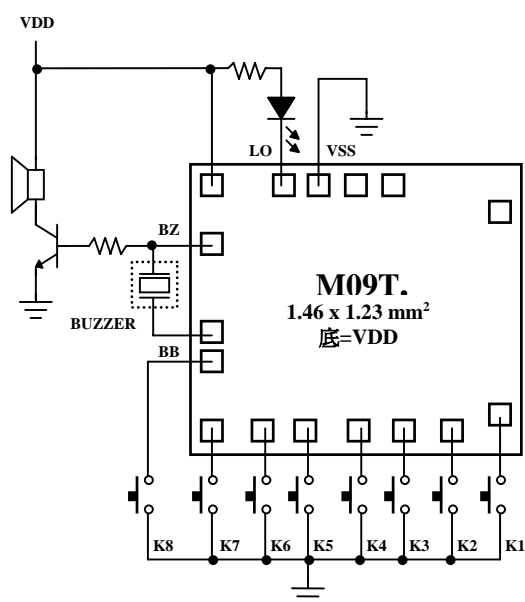

\*All specs and applications shown above subject to change without prior notice.

( 以上電路及規格僅供參考,本公司得逕行修正 )



SOUND EFFECT

M09T.



MOBILE PHONE

大哥大專用 IC

**PAD ASSIGNMENT & POSITION**

UNIT : um

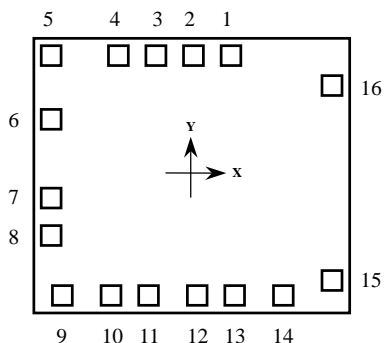

No.	NAME	X	Y
1	TE	166.5	489
2	T2	12	489
3	VSS	-141	489
4	LED	-306.75	489
5	VDD	-607.5	489
6	BZ	-607.5	294
7	BB	-607.5	-57.75
8	K8	-607.5	-215.25
9	K7	-567.75	-489.75
10	K6	-346.5	-489.75
11	K5	-196.5	-489.75
12	K4	24.75	-489.75
13	K3	174.75	-489.75
14	K2	396	-489.75
15	K1	607.5	-418.5
16	T1	606.75	336

\* CHIP SIZE ~ 1.46 x 1.23 mm<sup>2</sup>

\* IC substrate should be connected to VDD in PCB (PCB 上 IC 必須接 VDD)