



COST-EFFECTIVE PHOTOELECTRIC SMOKE DETECTOR

GENERAL DESCRIPTION

The M75210 is a very low-power IC providing all of the required features for a photoelectric type smoke detector. It is designed for operate at supply voltage as low as 2.7V and suited to 3V Lithium battery powered application. A variable-gain photo amplifier can be directly interfaced to an infrared emitter / detector pair. The amplifier gain levels are determined by two external capacitors that are then internally selected depending on the operating mode. Low gain is selected during standby. During a local alarm this low gain is increased (internally) by ~ 10% to reduce false triggering. High gain is used during the push-button test and during standby to periodically monitor the chamber sensitivity. The internal oscillator and timing circuitry keeps standby power to a minimum by sensing for smoke every 10 seconds in a 100 μs window.

FEATURES

- Operating voltage range 2.7V ~ 5V
- Local or Remote Smoke Alarm output.
- Low-Battery Trip Point Set Externally
- Power-on Reset.
- Built-in circuits to reduce false triggering.
- Average Supply Current: 4 μA @VDD=3.0V
- ESD-Protection circuitry on all pins.

APPLICATIONS

- Smoke detector.

PIN ASSIGNMENT

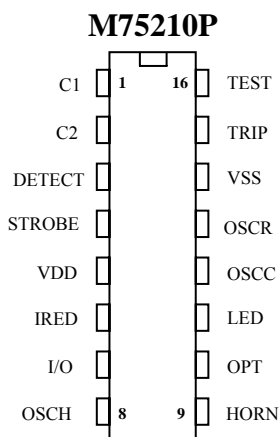



COST-EFFECTIVE PHOTOELECTRIC SMOKE DETECTOR

PIN AND CIRCUIT DESCRIPTION

Pin No	Pin Name	Description
1	C1	A capacitor connected to this pin determines the gain of the photo amplifier during the push-to-test mode and during the chamber monitor test. A typical value for this high-gain mode is $0.047 \mu\text{F}$ but should be selected based on the photo chamber background reflections reaching the detector and the desired level of sensitivity. $A_e \cong 1 + (C1 / 10)$ where C1 is in pF. A_e should not exceed 10,000.
2	C2	A capacitor connected to this pin determines the gain of the photo amplifier during standby. A typical value for this low-gain mode is 4700pF but should be selected based on a specific photo chamber and the desired level of sensitivity to smoke. $A_e \cong 1 + (C2 / 10)$ where C2 is in pF. A_e should not exceed 10,000.
3	DETECT	This is the input to the photo amplifier and is connected to the anode of the photo diode. The photo diode is operated at zero bias and should have low dark leakage current and low capacitance.
4	STROBE	This output provides a strobed, regulated voltage of 2V. The plus side of all internal and external photo amplifier circuitry is referenced to this pin.
5	VDD	This pin is connected to the most-positive supply potential and can range from 2.7V to 5V with respect to VSS.
6	IREDD	This output provides a pulsed base current for the external NPN transistor, which drives the IR emitter. The NPN transistor's beta should be greater than 100. To minimize noise impact, the IREDD output is not active when the horn and visible LED outputs are active.
7	I/O	A connection at this pin allows multiple smoke detectors to be interconnected. If a local smoke condition occurs, this pin is driven high. As an input, this pin is sampled nominally every 1.35 seconds during standby. Any local-alarm condition causes this pin to be ignored as an input. This pin also has an on-chip pull-down resistor and must be left unconnected if not used. In application, there is a series current-limiting resistor to other smoke alarms.
8	OSCH	Low-cost RC oscillator and sets the internal alarm frequency.
9	HORN	A continuous modulated tone indicates either a local or remote alarm condition. A short (10ms) chirp indicates a low-battery chirp occurs almost simultaneous with the visible LED flash.
10	OPT	OPT select stand-by Led flash cycle, when connect to VSS=43 second, when connect to VDD=8 second
11	LED	This open-drain NMOS output is used to directly drive a visible LED. The LED also indicates detector status as follows (with component values as in the typical application, all times nominal): Standby — Pulses every 43 seconds. Test Mode — Pulses every 0.67 seconds. Local Smoke — Pulses every 0.67 seconds. Remote Alarm — No pulses.
12	OSCC	A capacitor between this pin and VDD, along with a parallel resistor, forms part of a two-terminal oscillator and sets the internal clock low time. With component values as shown, this nominal time is 11 ms and essentially the oscillator period.
13	OSCR	A resistor between this pin and OSCC (pin 12) is part of the two-terminal oscillator and sets the internal clock high time, which is also the I _{REDD} pulse width. With component values as shown, this nominal time is $105 \mu\text{s}$.
14	VSS	This pin is connected to the most negative supply potential (usually ground).
15	TRIP	This pin is connected to an external voltage which determines the low-supply alarm threshold. The trip voltage is obtained through a resistor divider connected between the VDD and LED pins. The low-supply alarm threshold voltage (in volts) $\cong (1.4 * R13 / R14) + 1.4$ where R13 and R14 are in the same units.
16	TEST	This pin has an internal pull-down device and is used to manually invoke a test mode. The Push-to-Test Mode is initiated by a high logic level on this pin (usually the depression of a normally open push-button switch to VDD). After one oscillator cycle, I _{REDD} pulse every 336 ms (nominal) and amplifier gain is increased by internal selection of C1. Background reflections in the smoke chamber can be used to simulate a smoke condition. After the second I _{REDD} pulse, a successful test (two consecutive simulated smoke conditions) activates the horn drivers and the I/O pin. When the push-button is released, the input returns to VSS due to the internal pull down. After one oscillator cycle, the amplifier gain returns to normal and after two additional I _{REDD} pulse (less than one second), the device exits this mode and returns to standby.



COST-EFFECTIVE PHOTOELECTRIC SMOKE DETECTOR

FUNCTIONAL BLOCK DIAGRAM

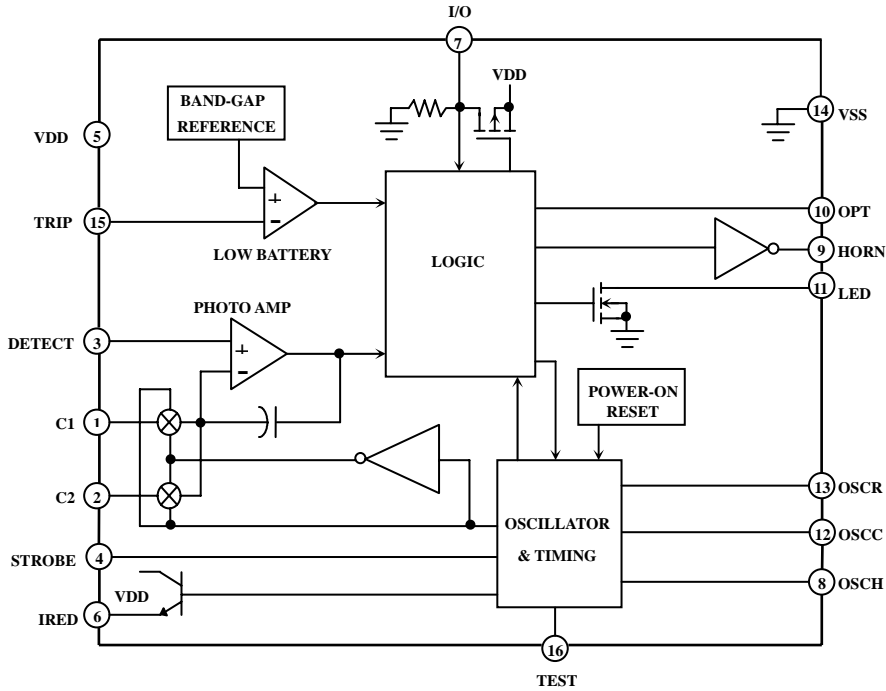

LOCAL ALARM TIMING DIAGRAM (NOT TO SCALE) :

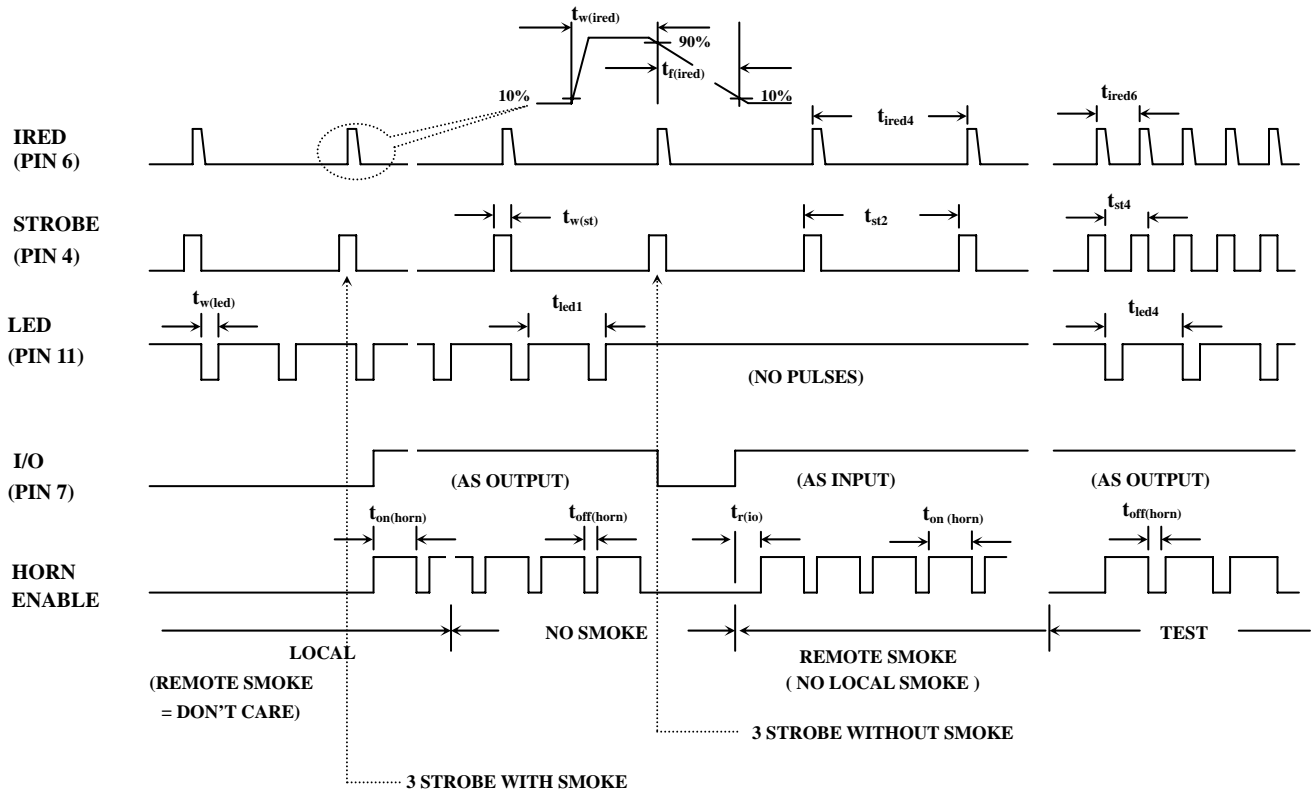



COST-EFFECTIVE PHOTOELECTRIC SMOKE DETECTOR

STANDBY TIMING DIAGRAM (NOT TO SCALE) :

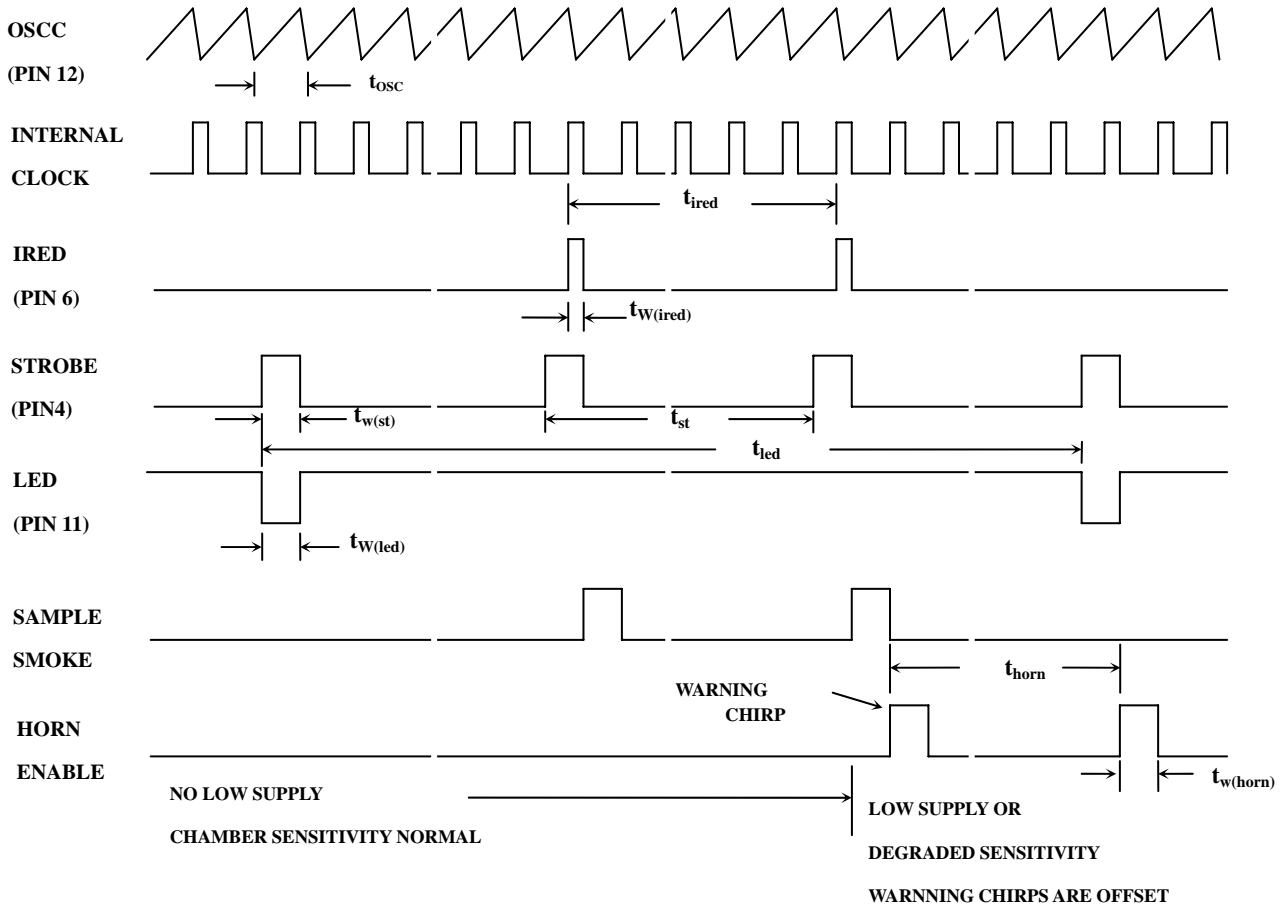

HORN MODULATION PATTERN

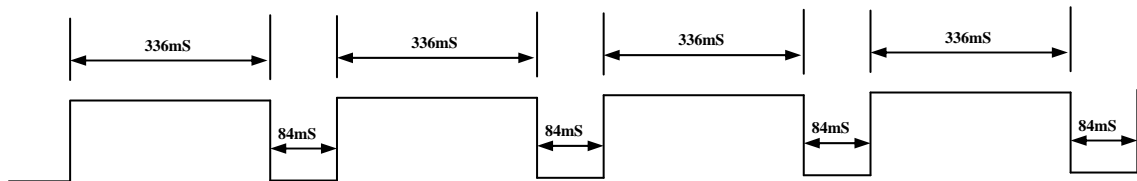



COST-EFFECTIVE PHOTOELECTRIC SMOKE DETECTOR

ABSOLUTE MAXIMUM RATING

Parameter	Sym.	Rating	Unit
Supply Voltage Range	V _{DD}	-0.5 ~ 5	V
Input Voltage Range	V _{IN}	-0.3 to V _{DD} + 0.3	V
Input Current	I _{IN}	10	mA
Operating Temperature Range	T _A	-10 ~ 60	°C
Storage Temperature Range	T _S	-55 to 125	°C

DC ELECTRICAL CHARACTERISTICS

(T_A = -25°C ~ 75°C)

Characteristics	Sym.	Pin	V _{DD}	Min.	Typ.	Max.	Unit	Conditions
Supply Voltage	V _{DD}		—	2.7	3	5.0	V	
Operating Supply Current	I _{DD}		3	—	—	4.5	μA	Average Standby
			3	—	—	2.0	mA	During Strobe ON, I _{RED} OFF
			3	—	—	3.0	mA	During Strobe ON, I _{RED} ON
Low-Level Input Voltage	V _{IL}	7	3	—	—	1.0	V	
High-Level Input Voltage	V _{IH}	7	3	2.0	—	—	V	
Input Leakage High	I _{IH}	12	3	—	—	100	nA	V _{IN} =V _{DD} , Strobe Active, Pin12 @V _{DD}
		15	3	—	—	100	nA	V _{IN} =V _{DD}
Input Leakage Low	I _{IL}	12	3	—	—	-100	nA	V _{IN} =V _{ST} , Strobe Active, Pin12 @V _{DD}
		7	3	—	—	140	μA	No Local Smoke, V _{IN} =17V(@V _{DD} =12V)
Low-Level Output Voltage	V _{OL}	11	3	—	—	0.6	V	I _O = 10mA
		13	3	—	0.5	—	V	I _O = 5mA
Strobe Output Voltage	V _{ST}	4	3	—	—	V _{SS} +0.1	V	Inactive, I _O = -1 μA
			3	1.7	—	2.3	V	Active, I _O = 100 μA to 500 μA
I _{RED} Output Voltage	V _{IRED}	6	3	—	—	0.1	V	Inactive, I _O = 1mA, T _A = +25°C
			3	0.9	1.2	1.4	V	Active, I _O = -6mA, T _A = +25°C
Line Regulation	ΔV _{IRED} (ΔV _{DD})		—	—	-35	—	dB	Active, V _{DD} = 4V to 6V
High-Level Output Voltage	I _{OH}	7	3	-4.0	—	—	mA	V _{DD} = Alarm, I/O active, V _O = V _{DD} -2V
OFF Leakage Current High	I _{OZ}	11	3	—	—	1.0	μA	V _O = V _{DD}
OFF Leakage Current Low	I _{OZ}	11	3	—	—	-1.0	μA	V _O = V _{SS}
Low V _{DD} Alarm Threshold	V _{DD} (th)		—	2.55	2.7	2.85	V	
Common Mode Voltage	V _{IC}	1, 2, 3	—	1.0	—	2.0	V	Any Alarm Condition
Smoke Comparator Ref. Volt.	V _{REF}	Int.	—	1.2	—	1.6	V	Any Alarm Condition

* Limits over the operating temperature range are based on characterization data.

Characteristics are production tested at +25°C.

Typical values are at +25°C and are given for circuit design information only.



COST-EFFECTIVE PHOTOELECTRIC SMOKE DETECTOR

AC ELECTRICAL CHARACTERISTICS

(TA= -25°C ~ 75°C)

Characteristics	Sym.	V _{DD}	Min.	Typ.	Max.	Unit	Conditions
Oscillator Period	T _{OSC}	3	9.4	10.5	11.5	ms	
Led Pulse Period	T _{LED1}	3	38.9	43	47.1	s	No Local or Remote Smoke
	T _{LED2}	3	None	—	—	s	Remote Smoke only
	T _{LED3}	3	0.6	0.67	0.74	s	Local Smoke or Test
Led Pulse Width	T _{W(LED)}	3	9.5	10.5	11.5	ms	
Strobe Pulse Period	T _{ST1}	3	9.6	10.5	11.9	s	No Local or Remote Smoke
	T _{ST2}	3	9.6	10.5	11.9	s	Remote Alarm
	T _{ST3}	3	38.9	43	47.1	s	Chamber Test or Low Supply Test ,No Local Alarm
	T _{ST4}	3	300	336	370	ms	Pushbutton Test , No Alarm
Strobe Pulse Width	T _{W(ST)}	3	9.5	10.5	11.5	ms	
I _{RED} Pulse Period	T _{IRED1}	3	9.6	10.5	11.9	s	No Local or Remote Smoke
	T _{IRED2}	3	9.6	10.5	11.9	s	Remote Alarm
	T _{IRED3}	3	38.9	43	47.1	s	Chamber Test , No Local Alarm
	T _{IRED4}	3	300	336	370	ms	Pushbutton Test , No Alarm
I _{RED} Pulse Width	T _{W(IRED)}	3	94	104	116	μs	
I _{RED} Rise Time	T _{r(IRED)}	3	—	—	30	μs	10% to 90%
I _{RED} Fall Time	T _{f(IRED)}	3	—	—	200	μs	90% to 10%
I/O to Active Delay	T _{d(IO)}	3	—	0	—	s	Local Alarm
Rising Edge on I/O to Alarm	T _{r(IO)}	3	—	—	1.65	s	No Local Alarm
Horn Warning Pulse Period	T _{HORN}	3	38.9	43	47.1	s	Low Supply and Degraded Chamber Sensitivity
Horn Warning Pulse Width	T _{W(HORN)}	3	9.5	10.5	11.5	ms	Low Supply and Degraded Chamber Sensitivity
Horn ON Time	T _{ON(HORN)}	3	300	336	370	ms	Local or Remote Alarm
Horn OFF Time	T _{OFF1(HORN)}	3	75	84	93	ms	Local or Remote Alarm

* Limits over the operating temperature range are based on characterization data.

Characteristics are production tested at +25°C.

Typical values are at +25°C and are given for circuit design information only.



COST-EFFECTIVE PHOTOELECTRIC SMOKE DETECTOR

APPLICATION DIAGRAM

STAND-ALONE :

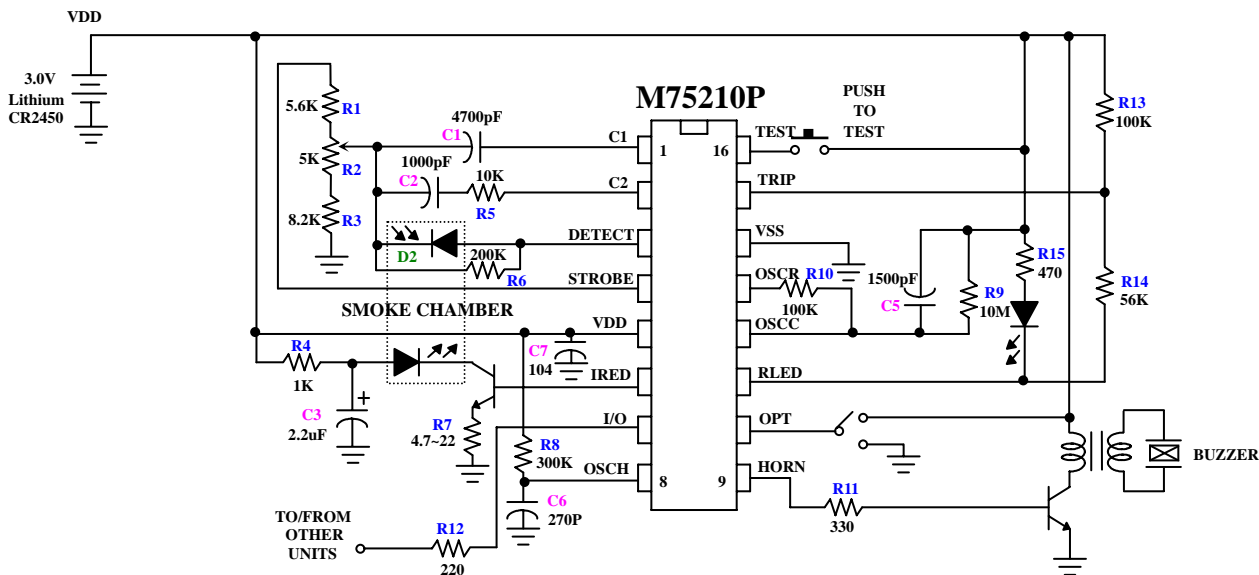

* C2 and R7 are used for coarse sensitivity adjustment. Typical values are shown.

NET WORK :

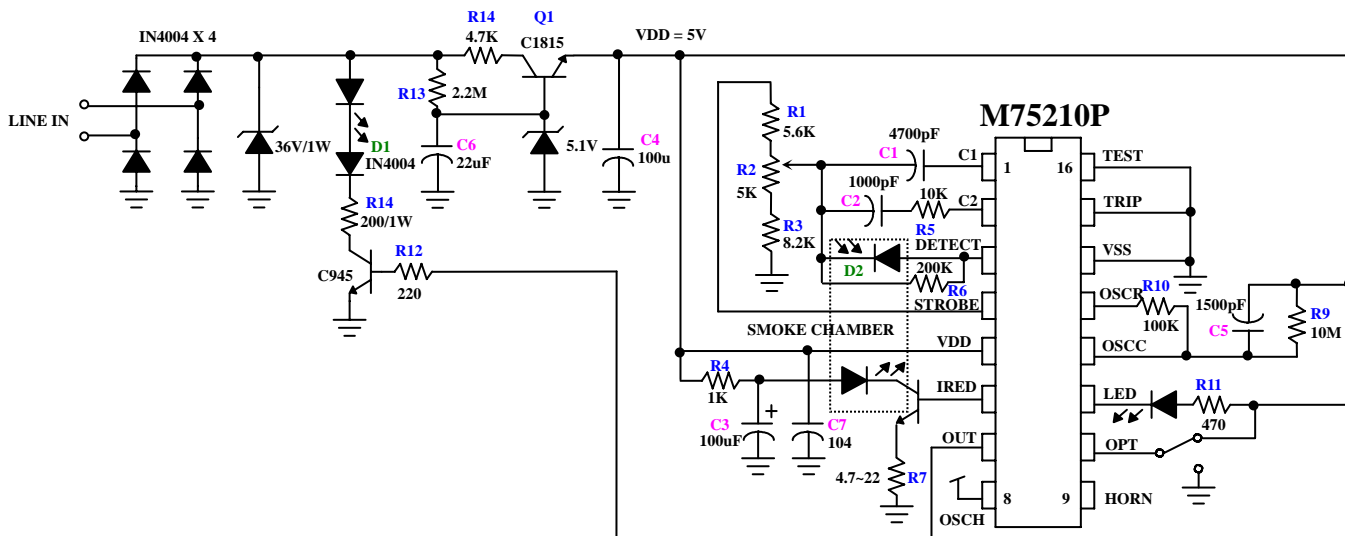

* C2 and R7 are used for coarse sensitivity adjustment. Typical values are shown.

* All specs and applications shown above subject to change without prior notice.

(以上電路及規格僅供參考,本公司得逕行修正)

COST-EFFECTIVE PHOTOELECTRIC SMOKE DETECTOR

CALIBRATION

To facilitate checking the sensitivity and calibrating smoke detectors, the M75210 can be placed in a calibration mode. In this mode, certain device pins are controlled/reconfigured as shown in **Table 1**. To place the part in the calibration mode, pin 16 (Test) must be middle of VDD for at least one cycle on the OSC pin.

In the calibration mode, the IRED pulse happens at every clock cycle and strobe is always on (active high). Also, Low Battery and supervisory tests are disabled in this mode.

Table 1 Configuration of Pins in the Calibration Mode

Description	Pin	Comment
I/O	7	Disabled as an output. Forcing this pin high places the photo amp output on pin 1 or 2, as determined by Low-Supply Trip. The amp's output appears as pulses and is referenced to VSS.
Trip	15	If the I/O pin is high, pin 15 controls which gain capacitor is used. Low: normal gain, amp output on pin 1. High: supervisory gain, amp output on pin 2.
OPT	10	Driving this input low enables hysteresis (10% gain increase) in the photo amp; pin 15 must be low.
OSCC	12	Driving this input high brings the internal clock high. Driving the input low brings the internal clock low. If desired, the RC network for the oscillator may be left intact; this allows the oscillator to run similar to the normal mode of operation.
Horn	8	This pin becomes the smoke comparator output. When the OSC pin is toggling, positive pulses indicate that smoke has been detected. A static low level indicates no smoke.
OSCH	9	This pin becomes the smoke integrator output. That is, two consecutive smoke detections ON (static high level) and two consecutive no-detections for .off. (static low level).

RECOMMENDED PCB LAYOUT

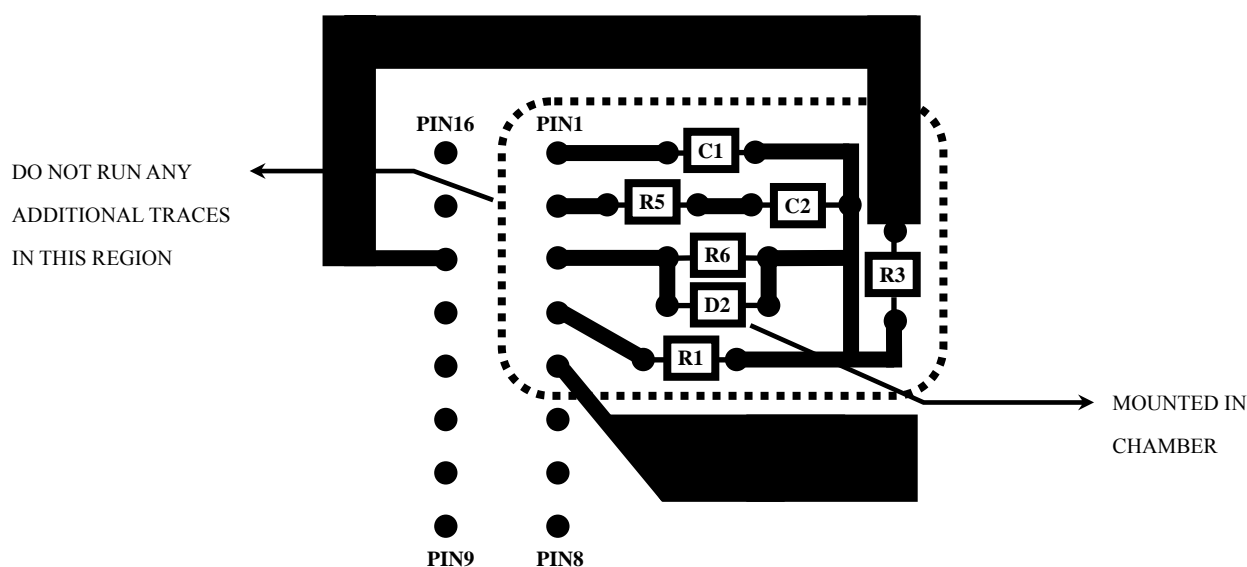

Notes : Illustration is bottom view of layout using a Dip. Top view for SOIC layout is mirror image. Optional potentiometer R2 is not illustrated drawing is not to scale. Leads on D2, R6, R1, and R3 and their associated traces must be kept as short as possible. This practice minimizes noise pick-up. Pin 3 must be decoupled from all other traces.