

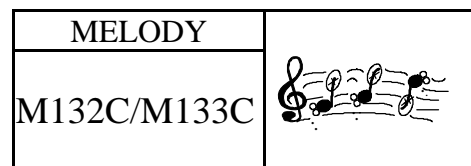

CDS, OSH & ON/OFF  
With 2 LEDs  
128 Note Melody IC

M132C 內建振盪  
M133C 可調頻率  
128 音符 + 2 LED



### FEATURES 功能敘述

- Rosc : INT. / EXT. (mask option)
- Separate LED and Buzzer and Motor Driver.
- LED : 互閃 ( 2.2 Hz ).  
: 互閃 ( ASYNC ).  
: L2 : ASYNC , L1 : Active Low.  
(mask option)
- Mode : OSH , LHI , LH II , ON/OFF ( Suffix-X ).

**M132C** Int. Rosc

**M133C** Ext. Rosc

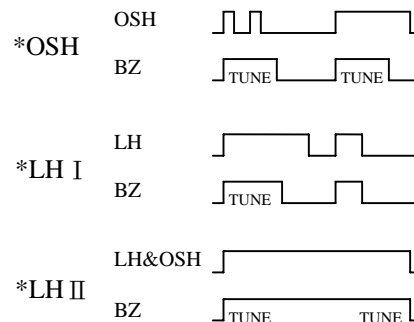

### APPLICATION 產品應用

- Toys, Key chain etc..

### ELECTRICAL CHARACTERISTICS 電氣規格

( @  $V_{DD}=3V$  unless otherwise specified )

Characteristics	Sym.	Min.	Typ.	Max.	Unit	REMARKS
工作電壓 Operating Voltage	$V_{DD}$	—	3	4.5	V	
工作電流 Operating Current	$I_{OP}$	—	0.1	0.5	mA	No load
靜態電流 Quiescent Current	$I_{SB}$	—	1	5	uA	
推動電流 BZ Driving Current	$I_O$	1	—	—	mA	@ $V_{DS}=1V$
推動電流 LO Driving Current	$I_{OL}$	6	—	—	mA	@ $V_{DS}=1.2V$
振盪頻率 Oscillator Frequency	$F_{OSC}$	—	100	—	KHz	Internal $\pm 30\%$
工作溫度 Operating Temperature	Temp.	0	25	60	$^{\circ}C$	

### APPLICATION DIAGRAM 參考電路圖

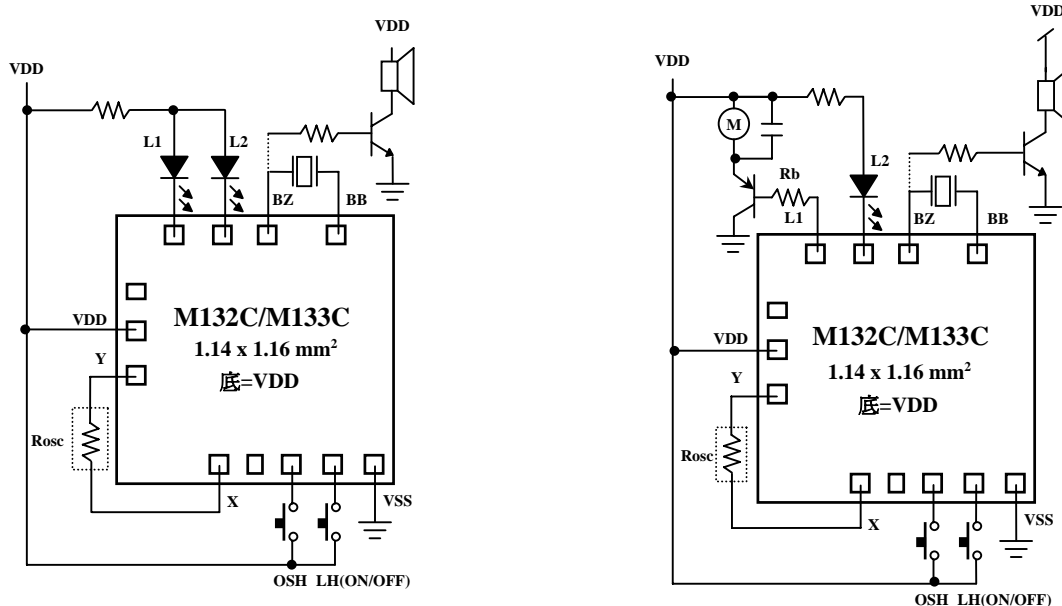

\*All specs and applications shown above subject to change without prior notice.

( 以上電路及規格僅供參考,本公司得逕行修正 )



~ 華半導體股份有限公司  
MOSDESIGN SEMICONDUCTOR CORP.

TAIPEI : TEL : 886-2- 22783733

FAX : 886-2- 22783633

H.K. : TEL : 852- 27569109

FAX : 852- 27566961

CDS, OSH & ON/OFF

With 2 LEDs

128 Note Melody IC

M132C 內建振盪

M133C 可調頻率

128 音符 + 2 LED

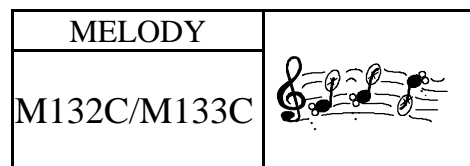

### PAD ASSIGNMENT & POSITION

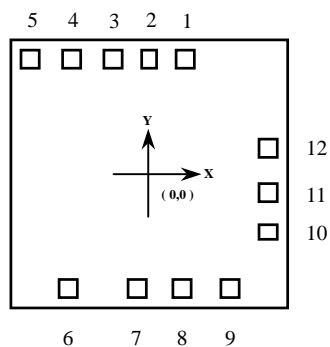

UNIT : um

No.	NAME	X	Y
1	X	201	454
2	TO	47	456
3	OSH	-103	454
4	LH	-275	454
5	VSS	-447	454
6	BB	-382	-408
7	BZ	-95	-408
8	L2	91	-404
9	L1	290	-404
10	TE	443	-258
11	VDD	446	-93
12	Y	446	88

\* CHIP SIZE ~ 1.14 x 1.16 mm<sup>2</sup>

\* IC substrate should be connected to VDD in PCB (PCB 上 IC 必須接 VDD)