

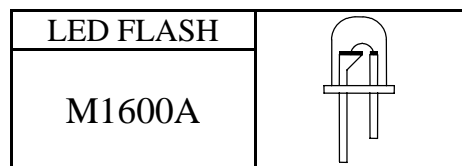

ON/OFF, OSH
RANDOM/SEQUENCE

6 LED 閃燈 IC



FEATURES 功能敘述

- ON/OFF : ON/OFF toggle. Default ON.
- OSH : One-Shot.
- RD/SEQ : Random/Sequence. Default RD.
- Power-on blinking.

P/N	Rosc	Fosc	Duty	OSH Cycle	LED Flash	LED Driver	FLED (Hz)	POWER
M1600A-1	Ext.		1/6	32	L1→L6	2/3	2.6	ON
M1600A-2	Int.		1/12	32	L6→L1	2/3	2.6	ON
M1600A-3	Ext.		1/6	32	L1→L6	1	2.6	ON
M1600A-4	Int.	65	1/12	32	L6→L1	1	2.6	ON
M1600A-4A	Int.	85	1/12	32	L6→L1	1	3.5	ON
M1600A-4B	Int.	85	1/12	32	L6→L1	1	3.5	OFF
M1600A-5	Ext.		1/6	16	L1→L6	1	2.6	ON
M1600A-6	Int.		1/12	8	L6→L1	1	2.6	ON

APPLICATION 產品應用

- Arcade game system, Toys.

ELECTRICAL CHARACTERISTICS 電氣規格

(@V_{DD}=3V unless otherwise specified)

Characteristics	Sym.	Min.	Typ.	Max.	Unit	REMARKS
工作電壓 Operating Voltage	V _{DD}	—	3	3.5	V	
工作電流 Operating Current	I _{OP}	—	0.1	0.5	mA	No load
靜態電流 Quiescent Current	I _{SB}	—	1	5	μA	
推動電流 Driving Current	I _{OL}	20	—	—	mA	@V _{DS} =1.2V
振盪頻率 Oscillator Frequency	F _{OSC}	—	65	—	KHz	External±30%
工作溫度 Operating Temperature	Temp.	0	25	60	°C	

APPLICATION DIAGRAM 參考電路圖

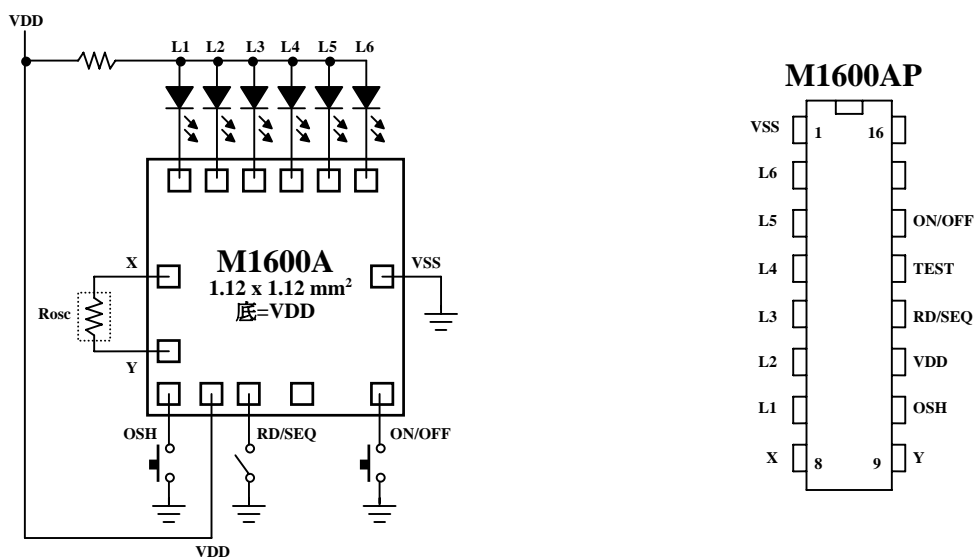

*All specs and applications shown above subject to change without prior notice.

(以上電路及規格僅供參考,本公司得逕行修正)



ON/OFF, OSH
RANDOM/SEQUENCE

6 LED 閃燈 IC

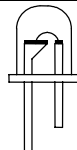
LED FLASH	
M1600A	

PAD ASSIGNMENT & POSITION

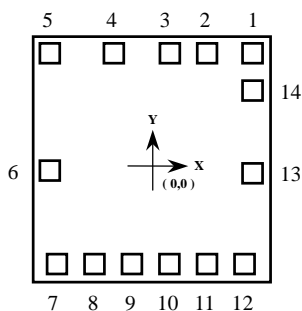

UNIT : um

No.	NAME	X	Y
1	OSH	433.5	432.75
2	VDD	252.75	432.75
3	RD/SEQ	99	432.75
4	TEST	-120	431.25
5	ON/OFF	-429	432.75
6	VSS	-430.5	-54
7	L6	-396.75	-431.25
8	L5	-238.5	-431.25
9	L4	-80.25	-431.25
10	L3	78	-431.25
11	L2	236.25	-431.25
12	L1	394.5	-431.25
13	X	433.5	-51.75
14	Y	433.5	-279

* CHIP SIZE ~ 1.12 x 1.12 mm²

* IC substrate should be connected to VDD in PCB (PCB 上 IC 必須接 VDD)

(以上電路及規格僅供參考,本公司得逕行修正)