



GENERAL DESCRIPTION 功能敘述

The M3DB/FB is a CMOS ASIC decoder. It will de-code the serial data from data input. The VT signal will go high and data will be copied to the output if address are checked the same. The address input are trinary i.e. LOW(0) 、 OPEN(X) and HIGH(1).

FEATURES 產品特長

- $3^{12} = 531,411$ codes, "0" 、 "X" 、 "1" Tri-states.
- 3 cycles checked each time
- S.O.Package : suffix-S.
- Address / Data types :
 - M3DB-L : Latch data outputs.
 - M3DB-M : Momentary data outputs
 - M3FB : Full address type

APPLICATIONS 產品應用

- Car/home alarm system, garage control etc..

BLOCK DIAGRAM 功能方塊圖

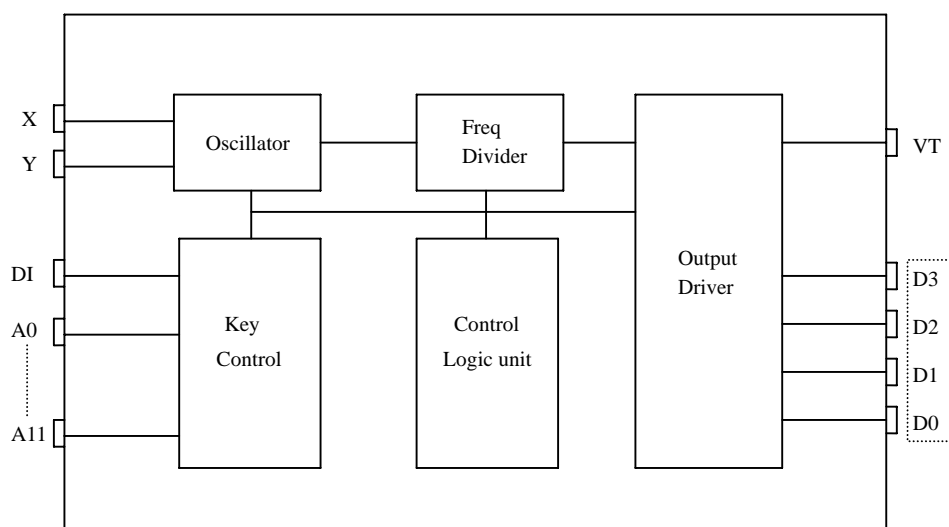

*All specs and applications shown above subject to change without prior notice.
(以上電路及規格僅供參考,本公司得逕行修正)



3 STATES DECODER
3 態解碼 IC

EN/DECODER

M3DB/FB

ABSOLUTE MAXIMUM RATING

(TA=25°C)

Parameter	Rating	Unit
Supply Voltage	-0.3 to 12	V
Input Voltage	-0.2~V _{DD} +0.2	V
Operating Temperature	-20 to 70	°C
Storage Temperature	-50 to 125	°C

ELECTRICAL CHARACTERISTICS

Characteristics	Sym.	Min.	Typ.	Max.	Unit	Conditions
Operating Voltage	V _{DD}	2.4	—	12	V	
Operating Current	I _{OP}	—	0.3	1	mA	No load
Quiescent Current	I _{SB}	—	1	10	μA	
Output Drive Current	I _O	—	2	—	mA	@V _{DS} =1.2V
Input Voltage	V _{IH}	V _{DD} -0.2	V _{DD}	V _{DD}	V	
	V _{IL}	V _{SS}	V _{SS}	V _{SS} +0.2		
Oscillator Frequency	Fosc	—	38	—	KHz	External±30%, Rosc=1.2MΩ

PIN DESCRIPTION

No.	M3DB	M3FB	Description
1~8	A0~A7	A0~A7	3 States address inputs
9	VSS	VSS	Negative power supply
10~13	D0~D3	A8~A11	Data outputs/Address inputs
14	DI	DI	Data input
15	X	X	Oscillator output
16	Y	Y	Oscillator input
17	VT	VT	Valid transmit
18	VDD	VDD	Positive power supply

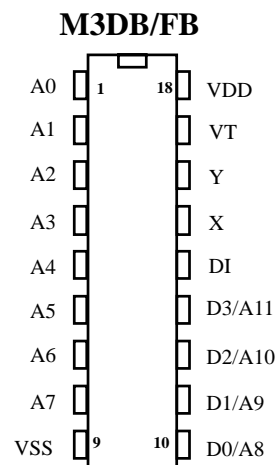



TIMING WAVEFORM

(1) Bit format

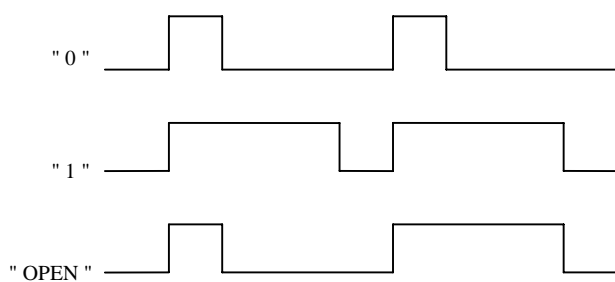

(2) TIMING DIAGRAM

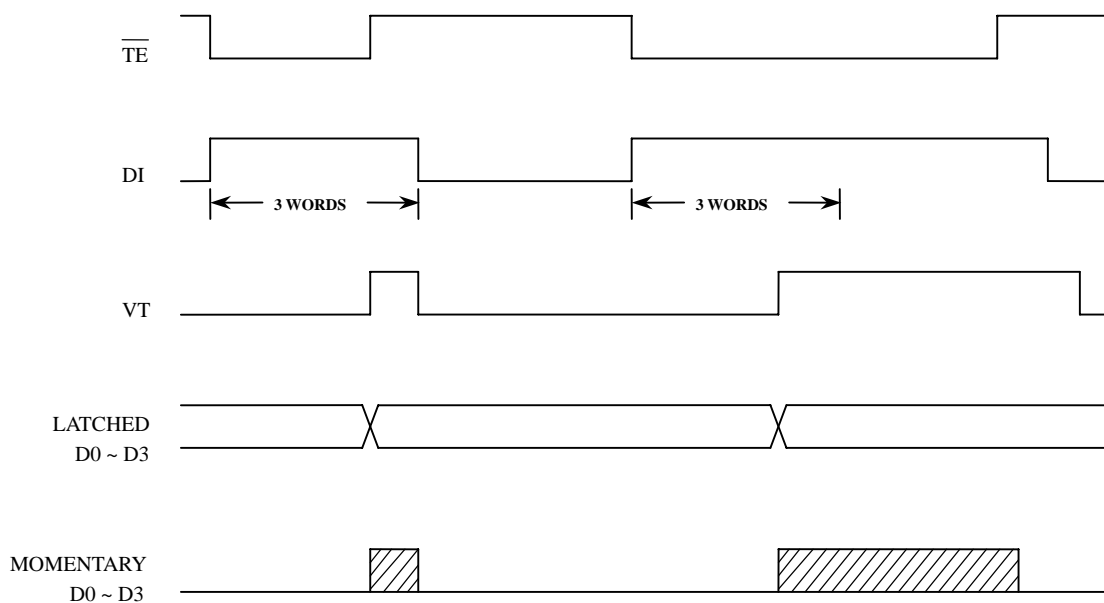



3 STATES DECODER

3 態 解 碼 IC

OPERATING FLOWCHART

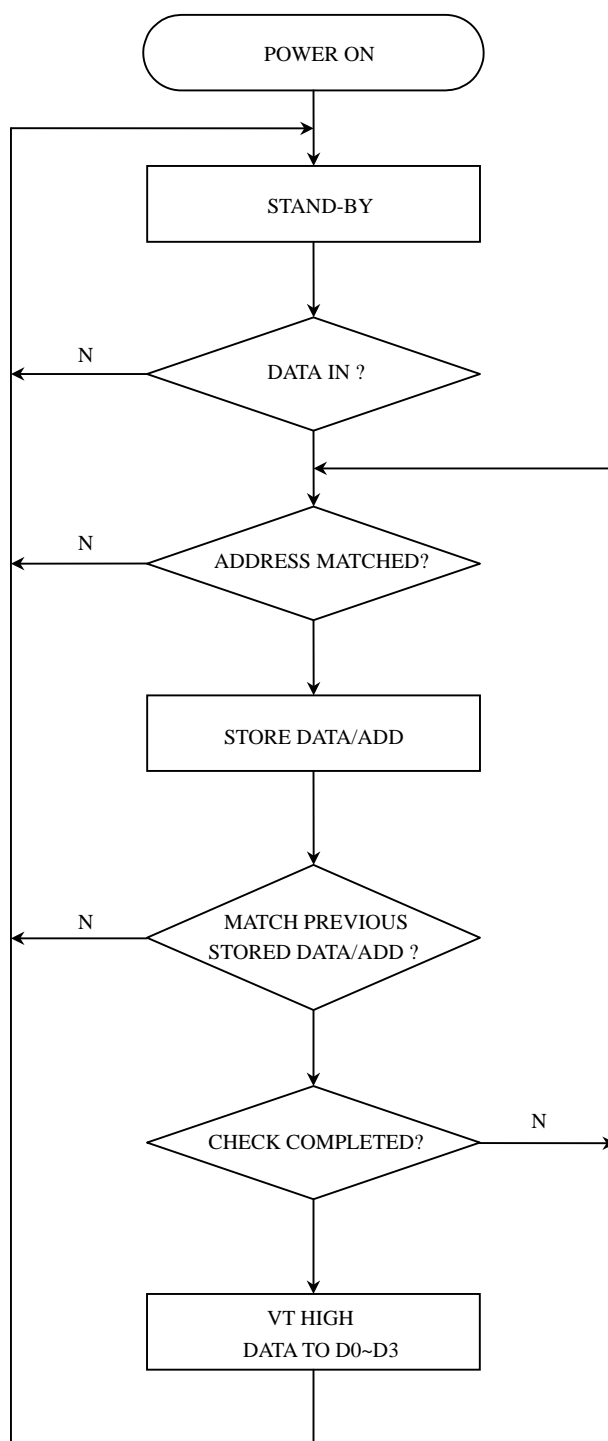



3 STATES DECODER
3 態 解 碼 IC

EN/DECODER

M3DB/FB

RECONNENDED OSCILLATOR PARAMETERS

Volt Rosc (KΩ)	M3DB/FB (KHz)							
	5V	6V	7V	8V	9V	10V	11V	12V
100K	367	387	402	418	433	445	456	467
240K	161	169	175	181	187	193	197	202
560K	77	81	83	86	89	91	94	95
910K	43	44	48	48	48	49	50	51
1M	43	44	46	47	49	50	51	52
1.5M	26	27	28	29	30	31	31	32
2M	20	21	22	23	23.5	24	24.6	25
3.3M	12.7	13	13.5	14	14.4	14.8	15.2	15.5
4.7M	8.7	9	9.2	9.6	9.8	10	10.3	10.5

DATA OUTPUT

M3E, (D0~D3)	M3DB/FB (D0~D3)
0 (VSS)	0 (VSS)
X (OPEN)	1 (VDD)
1 (VDD)	1 (VDD)
POWER ON	0 (VSS)

M3DB/FB Freq-Vdd Curve

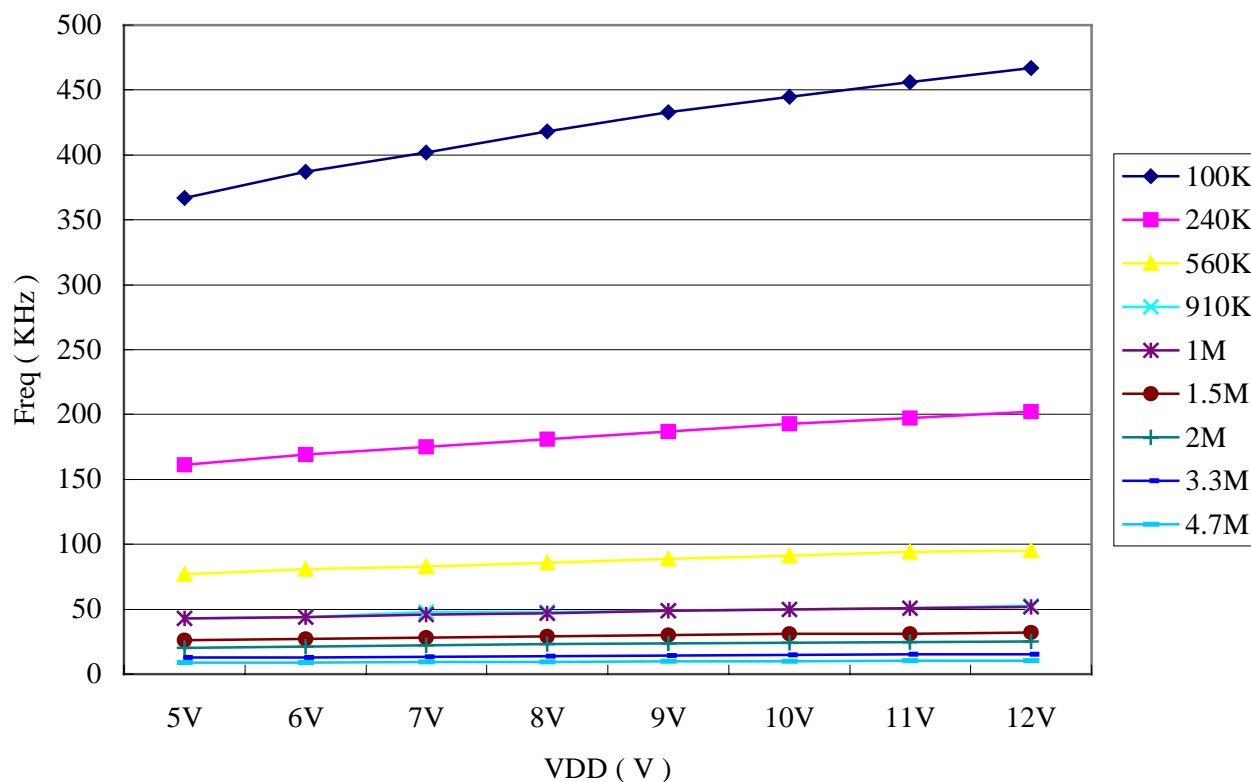



3 STATES DECODER
3 態解碼 IC

EN/DECODER

M3DB/FB

ADDRESS PIN INFORMATION

P/N	A0	A1	A2	A3	A4	A5	A6	A7	A8	A9	A10	A11
M3FB	A0	A1	A2	A3	A4	A5	A6	A7	A8	A9	A10	A11
M3DB-L1	A0	A1	A2	A3	A4	A5	A6	A7	A8	A9	A10	D0
M3DB-L2	A0	A1	A2	A3	A4	A5	A6	A7	A8	A9	D0	D1
M3DB-L3	A0	A1	A2	A3	A4	A5	A6	A7	A8	D0	D1	D2
M3DB-L4	A0	A1	A2	A3	A4	A5	A6	A7	D0	D1	D2	D3
M3DB-L5	A0	A1	A2	A3	A4	A5	A6	D0	D1	D2	D3	D5
M3DB-L6	A0	A1	A2	A3	A4	A5	D0	D1	D2	D3	D5	D6
M3DB-M1	A0	A1	A2	A3	A4	A5	A6	A7	A8	A9	A10	D0
M3DB-M2	A0	A1	A2	A3	A4	A5	A6	A7	A8	A9	D0	D1
M3DB-M3	A0	A1	A2	A3	A4	A5	A6	A7	A8	D0	D1	D2
M3DB-M4	A0	A1	A2	A3	A4	A5	A6	A7	D0	D1	D2	D3
M3DB-M5	A0	A1	A2	A3	A4	A5	A6	D0	D1	D2	D3	D5
M3DB-M6	A0	A1	A2	A3	A4	A5	D0	D1	D2	D3	D5	D6



3 STATES DECODER

3 態 解 碼 IC

M3DB/FB

APPLICATION DIAGRAM 參考電路圖 (DIP, SOP)

(1) DATA TYPE

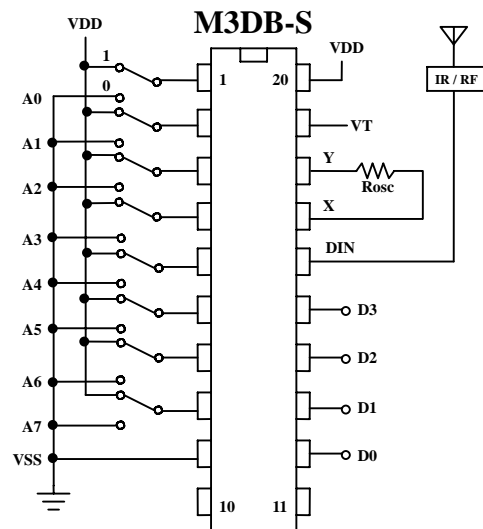
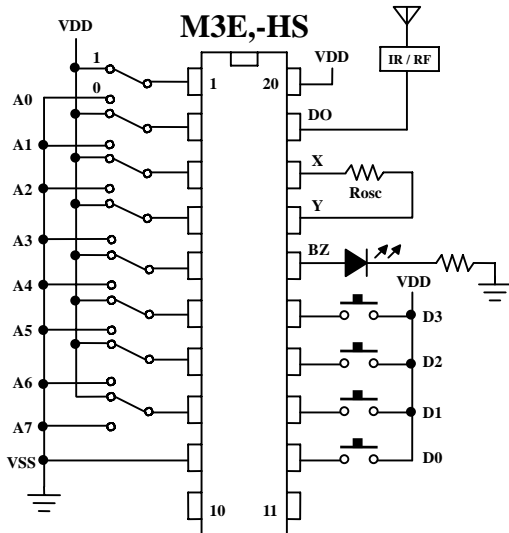
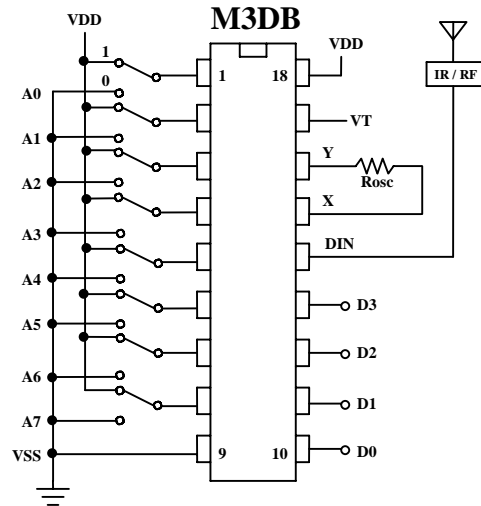
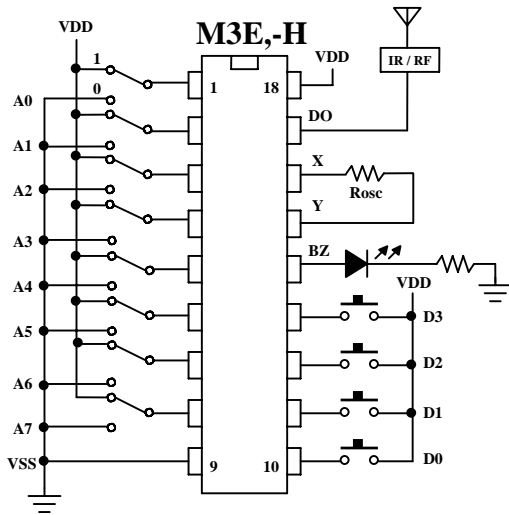



3 STATES DECODER

3 態 解 碼 IC

M3DB/FB

APPLICATION DIAGRAM 參考電路圖 (DIP, SOP)

(2) FULL ADDRESS TYPE

