



2 STATES DECODER

2 態 解 碼 IC

**GENERAL DESCRIPTION 功能敘述**

The M1DA/FA is a CMOS ASIC decoder. It will de-code serial data from data input. The VT signal will go high and data will be copied to the output if address are checked the same.

**FEATURES 產品特長**

- Same Rosc matched to the Encoder M1EA.
- $2^{12} = 4,096$  codes, "0"、"1" binary.
- 3 cycles checked each time.
- Address / Data types :
  - M1DA : 4 data type ( Latched ).
  - M1DA-M : Momentary data outputs.
  - M1FA : Full address type.

**APPLICATIONS 產品應用**

- Car/home alarm system, garage control etc..

**BLOCK DIAGRAM 功能方塊圖**

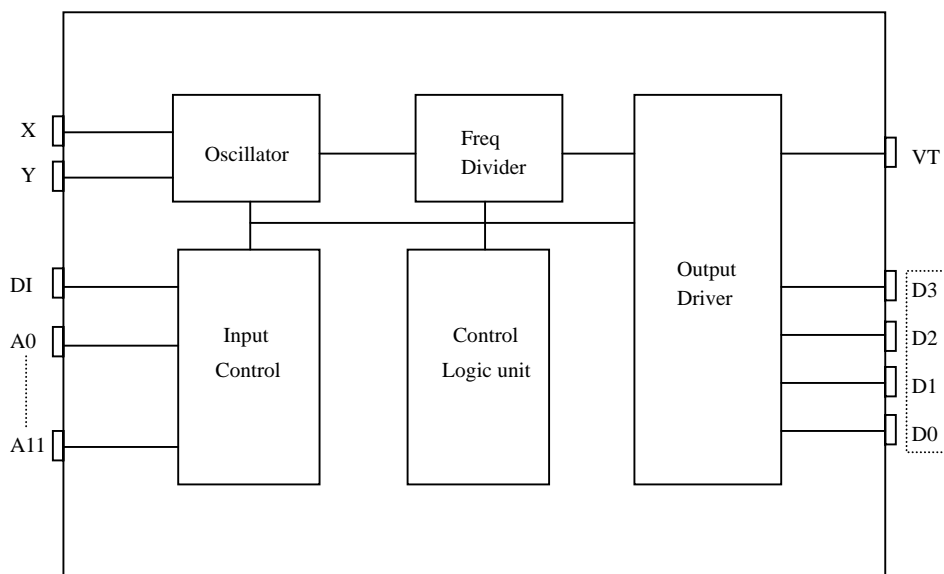

\*All specs and applications shown above subject to change without prior notice.  
( 以上電路及規格僅供參考,本公司得逕行修正 )



2 STATES DECODER  
2 態解碼 IC

EN/DECODE
<b>M1DA / FA</b>

**ABSOLUTE MAXIMUM RATING**

(TA=25°C)

Parameter	Rating	Unit
Supply Voltage	-0.3 to 12	V
Input Voltage	-0.2~V <sub>DD</sub> +0.2	V
Operating Temperature	-20 to 70	°C
Storage Temperature	-50 to 125	°C

**ELECTRICAL CHARACTERISTICS**

Characteristics	Sym.	Min.	Typ.	Max.	Unit	Conditions
Operating Voltage	V <sub>DD</sub>	2.4	—	12	V	
Operating Current	I <sub>OP</sub>	—	0.1	1	mA	No load
Quiescent Current	I <sub>SB</sub>	—	0.1	0.5	μA	
Output Drive Current	I <sub>O</sub>	—	2	—	mA	@V <sub>DS</sub> =1.2V
Input Voltage	V <sub>IH</sub>	V <sub>DD</sub> -0.2	V <sub>DD</sub>	V <sub>DD</sub>	V	
	V <sub>IL</sub>	V <sub>SS</sub>	V <sub>SS</sub>	V <sub>SS</sub> +0.2		
Oscillator Frequency	F <sub>osc</sub>	—	76	—	KHz	External±30%,R <sub>osc</sub> =270KΩ

**PIN DESCRIPTION**

No.	M1DA	M1FA	Description
1~8	A0~A7	A0~A7	2 States address inputs
9	VSS	VSS	Negative power supply
10~13	D0~D3	A8~A11	Data outputs/Address inputs
14	DIN	DIN	Data input
15	Y	Y	Oscillator output
16	X	X	Oscillator input
17	VT	VT	Valid transmit
18	VDD	VDD	Positive power supply

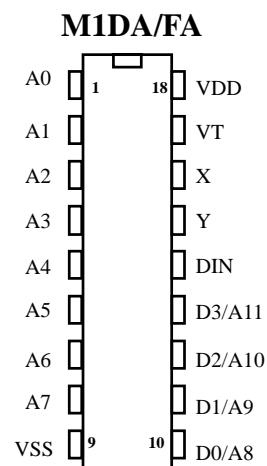



## TIMING WAVEFORM

### (1) BIT FORMAT

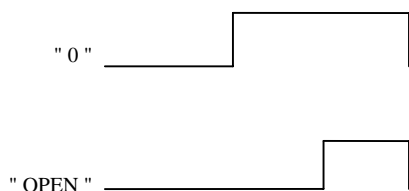

### (2) TIMING DIAGRAM

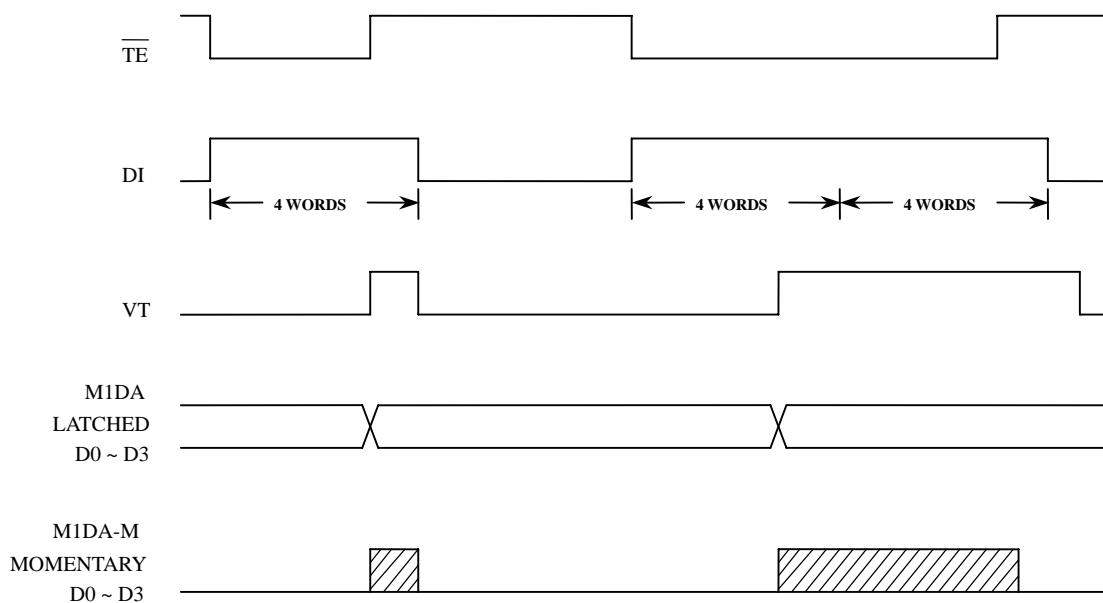



2 STATES DECODER

2 態 解 碼 IC

OPERATING FLOWCHART

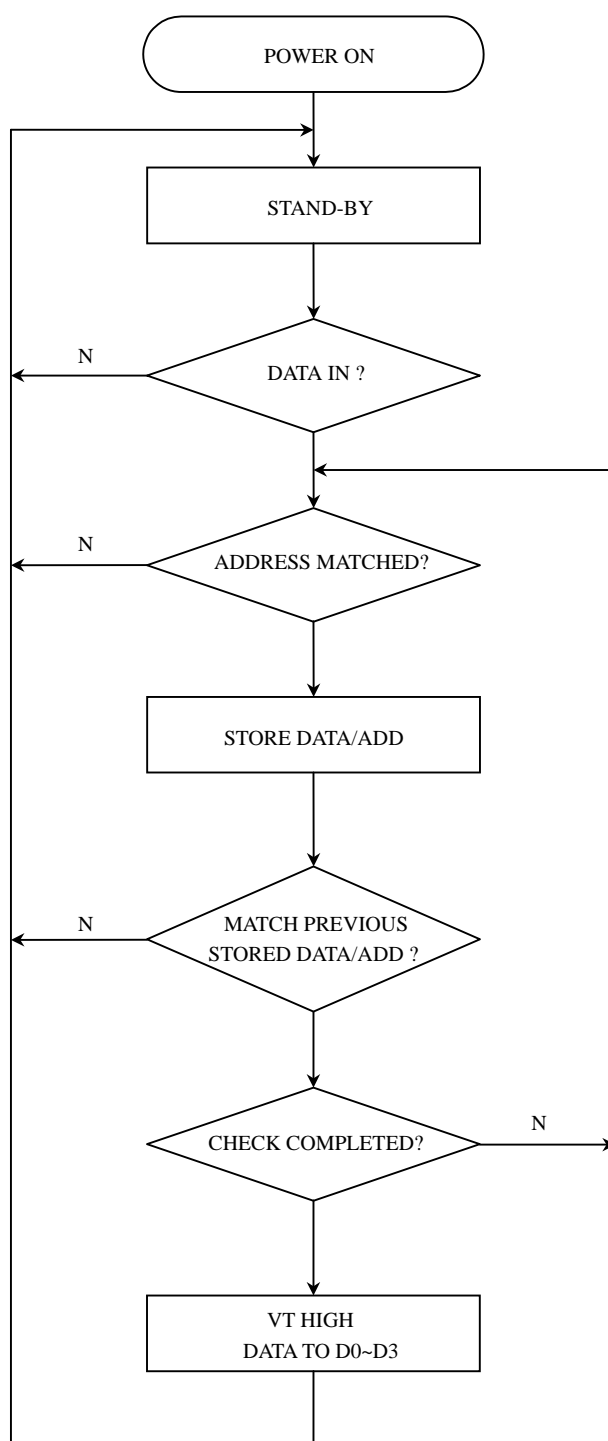



2 STATES DECODER

2 態 解 碼 IC

**M1DA / FA**

**RECONNENDED OSCILLATOR PARAMETERS**

Rosc (KΩ)	M1DA/FA (KHz)
75	246
82	235
91	210
100	192
120	161
150	129
180	108
200	98
220	88
270	71
300	65
330	59
360	53

**DATA OUTPUT**

M1EA (D0~D3)	M1DA/FA (D0~D3)
0 (VSS)	1 (VDD)
1 (OPEN)	0 (VSS)

**Freq-Rosc Chart**  
( VDD@12V )

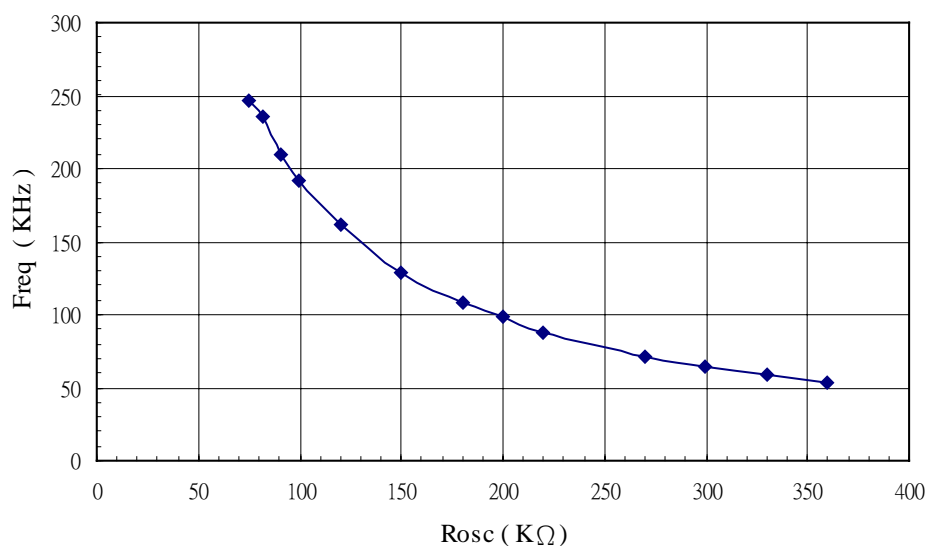



APPLICATION DIAGRAM 參考電路圖

(1) DATA TYPE

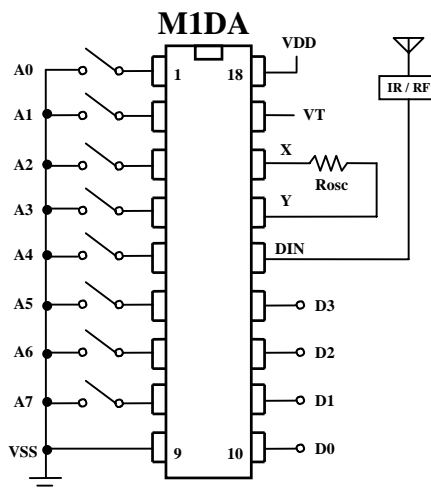
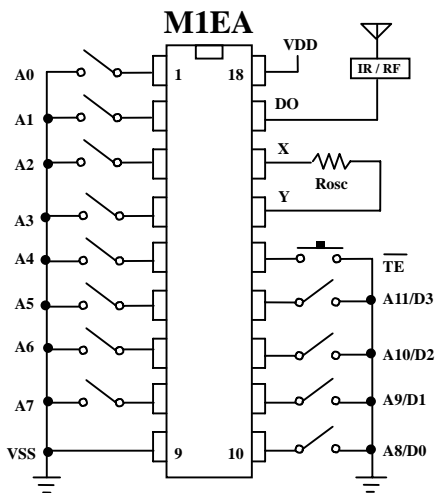

(2) FULL ADDRESS TYPE

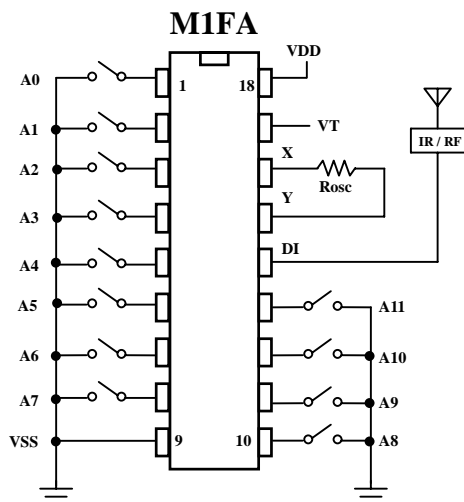
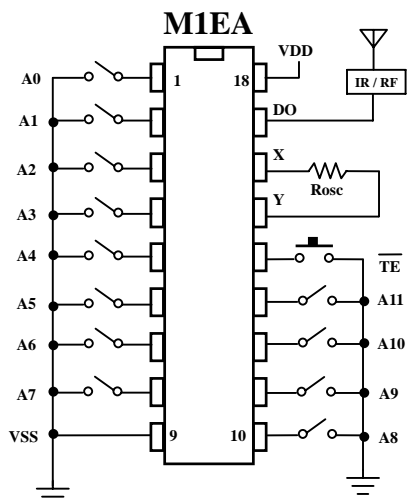



2 STATES DECODER

2 態解碼 IC

APPLICATION DIAGRAM 參考電路圖 (SOP PACKAGE)

(1) DATA TYPE

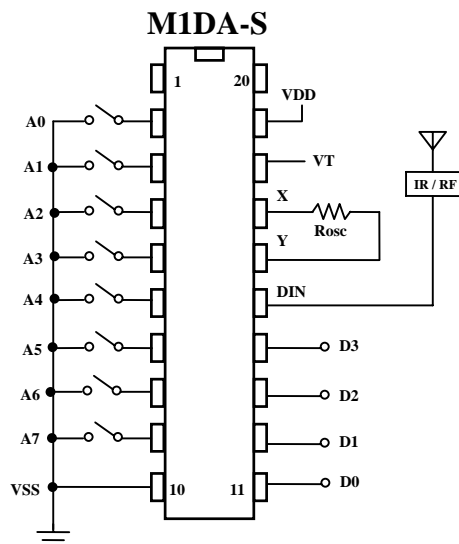
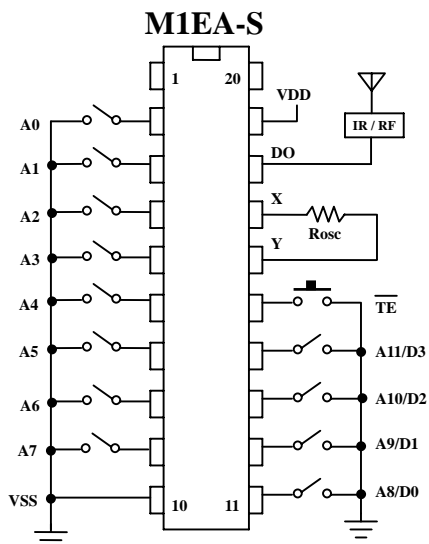

(2) FULL ADDRESS TYPE

